

MINI and MIX Series

I/O modules

User Manual

Modbus

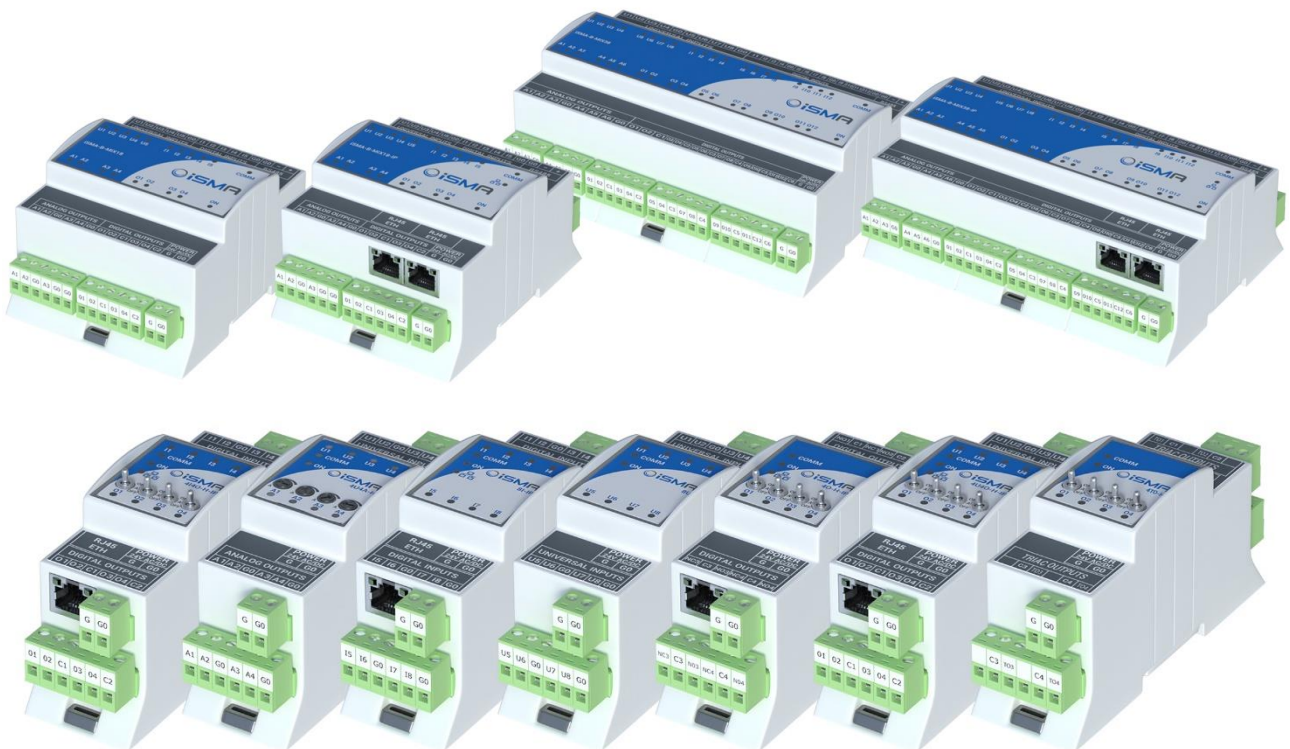

Global Control 5 Sp. z o.o.
Warsaw, Poland
www.gc5.pl

Table of contents

1	Introduction.....	5
1.1	Revision history	5
1.2	Safety rules	6
1.3	Technical specifications	7
1.4	Summary table for all modules	9
1.5	Dimensions	11
1.6	Power supply connection	12
1.6.1	DC power connection.....	12
1.6.2	AC power connection.....	12
1.7	Connecting the communication bus (RS485).....	12
1.8	LED Indicators	13
1.9	Grounding and shielding.....	14
1.10	RS485 network termination	14
1.11	Setting module address on modbus network	16
1.12	Baud rate selection	16
1.13	Protocol selection	17
1.14	Restoring the default settings	17
1.15	Default Settings.....	18
2	Configuration registers.....	19
2.1	Firmware version and module type (30001)	19
2.2	Module address (30002)	19
2.3	Baud rate and protocol (30003).....	20
2.4	Counter of received messages (30004).....	20
2.5	Counter of error messages (30006).....	20
2.6	Counter of sent messages (30008)	20
2.7	Up time (30012)	20
2.8	Hardware_version (30130).....	21
2.9	MAC_address (30131)	21
2.10	Device actions (40001).....	21
2.11	Baud rate (40136)	21
2.12	Stop bits (40137).....	21
2.13	Data bits (40138)	22
2.14	Parity bit (40139).....	22
2.15	Response delay time (40140).....	22
2.16	Watchdog time (40141).....	22
3	Local I/O	24
3.1	Universal Inputs connections	24
3.1.1	Connection of Universal Input to measure voltage 0 – 10V.....	24
3.1.2	Connection of the Universal Input to measure current 0 – 20 mA	24
3.1.3	Connection of Universal Input to measure the temperature	25
3.1.4	Connection of Universal Input as a Digital Input (Dry Contact).....	25
3.2	Universal Inputs MODBUS Registers	26
3.2.1	Status of Universal Inputs working as Digital Inputs (30017).....	26
3.2.2	Universal Input voltage (current) measure 1 - 8 (30071, 30073, 30075, 30077, 30079, 30087, 30089, 30091)	26
3.2.3	Universal Input temperature measurement 1 - 8 (30072, 30074, 30076, 30078, 30080, 30095, 30097, 30099)	26
3.2.4	Universal Input resistance measurement 1 - 8 (30103, 30104 – 30117, 30118).....	26
3.2.5	Universal Input configuration 1 - 8 (40151 – 40158).....	26
3.2.6	Filter time constant of the Universal Input 1 - 8 (40159 – 40166)	27
3.2.7	Resolution of the Universal Inputs (40167).....	27
3.3	Digital Inputs Connections	28
3.3.1	Connection of Digital Input (Dry Contact).....	28

3.4	Digital Input MODBUS Registers.....	28
3.4.1	State of Digital Inputs (30016).....	28
3.4.2	Counter 1 – 12 (40023, 40024 – 40045, 40046).....	28
3.4.3	Resetting the counters (40022).....	29
3.5	Analog Output Connections.....	29
3.5.1	Connection of 0-10V Analog Output.....	29
3.5.2	Connecting relay to Analog Output.....	29
3.5.3	Connecting an actuator to the Analog Output.....	30
3.6	Analog Output MODBUS Registers.....	30
3.6.1	State of Analog Outputs operating as Digital Outputs (40019).....	30
3.6.2	Value of 1-6 Analog Outputs (40121 – 40126).....	30
3.6.3	Default state of the Analog Outputs (digital) (40144).....	30
3.6.4	Default state of 1-6 Analog Outputs (40145 – 40150).....	31
3.6.5	Configuration mode of 1-6 Analog Outputs (40168 – 40173).....	31
3.6.6	Hand control status of analog outputs (30015).....	31
3.6.7	Hand control value of 1-4 Analog Outputs (30125 - 20128).....	32
3.7	Digital Output (relay) Connections.....	33
3.7.1	Connecting the solenoid valve to the Digital Output.....	33
3.7.2	Connecting a resistive load to the Digital Output.....	33
3.7.3	Connecting an inductive load to the Digital Output.....	33
3.8	Digital Output (relay) MODBUS Registers.....	34
3.8.1	State of Digital Outputs (40018).....	34
3.8.2	Default state of Digital Outputs (40143).....	34
3.8.3	Hand control status of Digital Outputs (30015).....	34
3.9	Triac Output Connections.....	35
3.9.1	Connecting the solenoid valve to the Triac Output.....	35
3.9.2	Connecting a resistive load to the Triac Output.....	35
3.10	Triac Output MODBUS Registers.....	36
3.10.1	State of Triac Outputs (40018).....	36
3.10.2	Default state of Triac Outputs (40143).....	36
3.10.3	Value of 1-4 Triac PWM Outputs (40121 – 40124).....	36
3.10.4	Default state of 1-4 Triac PWM Outputs (40145 – 40148).....	36
3.10.5	Configuration mode of 1-4 Triac Outputs (40168 – 40171).....	36
3.10.6	Hand control status of the Triac Outputs (30015).....	37
3.11	Special application modes for 4I40-H, 4I40-H-IP, 4U40-H, and 4U40-H-IP.....	38
3.11.1	Operation Mode registers (40176, 40180, 40184, and 40188).....	39
3.11.2	Time Value registers (40177,40181,40185,40189).....	43
3.11.3	Command register (40020).....	44
3.11.4	Block Inputs register (40021).....	44
3.11.5	Setpoint registers (40178, 40182, 40186, 40190).....	44
3.11.6	Differential registers (40179,40183,40187,40191).....	44
4	WEB Configuration - IP version only.....	45
4.1	Web server access.....	45
4.2	Device page.....	45
4.3	Local I/O status and configuration.....	46
4.3.1	Universal Inputs.....	46
4.3.2	Configuration of special application mode.....	47
4.3.3	Digital Inputs.....	48
4.3.4	Digital Outputs.....	48
4.3.5	Analog Outputs.....	49
4.4	RS485 Configuration.....	50
4.5	IP Configuration.....	51
4.6	Device management.....	52
4.7	Contact.....	52
5	Modbus TCP/IP modules.....	53
5.1	Modbus TCP/IP.....	53

5.2	Module as Modbus TCP/IP Gateway to RS485	53
6	List of all Modbus Registers	55
7	List of supported temperature sensors.....	64

1 Introduction

1.1 Revision history

Rev	Date	Description
1.0	2015.08.28	First edition
1.1	2016.02.01	<p>Reason for the creation of a new version of the document:</p> <ul style="list-style-type: none"> • In 12.2015 GC5, released a new hardware version of MIX module with a more powerful processor and a USB port. For this hardware, and for all MINI series devices we released 4.0 firmware which contains a bug fix, firmware improvements, and a rebuilt BACnet protocol (new object, COV). • As of 2016, all the modules purchased are equipped with improved versions of the relays, which allows for increasing the capacitive load. Details of the technical specifications added. • Note: This document was created for devices with firmware version 4.0 and above. For previous firmware version please read Modbus Manual version 1.0. • Changes in the Document: • Information about the capacitive load relay added to the technical specifications. • Information about load Triac Outputs added to the technical specifications. • Description of the new MINI module 4x Triac Outputs: 4TO-H and 4TO-H-IP added. • MINI - 4I40-H and 4I40-H-IP Module built-in application: Change of logic in the Time relay mode. Now, the timer counts from the falling edge (it used to start counting from the rising edge). • New gateway functionality blocking Send Modbus Error. • Tables with PT1000 and NI1000 updated with more accurate data with new FW measuring resistance at these sensors with the accuracy of 0.1 Ω.
1.2	2017.01.03	<p>Reason for the creation of a new version of the document:</p> <p>New functions:</p> <ul style="list-style-type: none"> • New HVAC functions: Heating and Cooling in 4U40, based on output thermostatic control with a setpoint and differential value setting; • New input mode for 4I40 added: Time Relay NC [ms], Time Relay NO and NC in seconds, Input Forwarding; • New input mode added for 4U40: Ordinary IO, Monostable Relay, Bistable Relay, Time Relay NO and NC [ms], Time Relay NO and NC in seconds, Input Forwarding, Heating, Cooling with corresponding BACnet objects and Modbus registers; • Output for resetting to default added after input mode change in 4U40 and 4I40; <p>Improvements:</p> <ul style="list-style-type: none"> • Improved BACnet COV Increment now can have values with the resolution of 0.1; • BACnet COV Increment access (read/write) through USB added; • Power Led added, flashing when the IO watchdog is triggered; • IO watchdog reset after read/write registers through USB modified; • Sensors added for detecting short circuit and disconnection, regardless of filter settings on universal inputs;

		<p>Bugs fixed:</p> <ul style="list-style-type: none"> Fixed bug with Stop bits, it was always 1;
1.3	2017.05.16	<p>Reason for the creation of a new version of the document:</p> <p>New functions:</p> <ul style="list-style-type: none"> Hardware Version information on the main tab on the web page and in the Modbus register added new action in Modbus register no 0 – enter the bootloader RS485 biasing control added for MINI modules with hardware version ≥ 2.0 (option unavailable in MIX modules) www page: RS485 Biasing Resistors activating option (appears only in MINI modules with hardware ≥ 2.0) <p>Improvements:</p> <ul style="list-style-type: none"> modules names on web page corrected (added -H for all modules with hand operation switches)
1.4	2017.12.07	<p>The reason for the creation of a new version of the document: On 07.12.2017, GC5 released a new firmware version 6.0 for MIX and MINI modules. New firmware contains a bug fix, improvements and changes in BACnet protocol, according to BACnet Testing Laboratories certification requirements.</p> <p>New functions:</p> <ul style="list-style-type: none"> Firmware Version 6.0 released with BACnet certification <p>Improvements:</p> <ul style="list-style-type: none"> fixed out of service flags in AO, BO and TO fixed overridden flags in AO, BO and TO fixed bug with number of counters for Binary input object (now variable is 32 bit) changed AO-1, BO-1, TO-1 HAND_STATUS Access to read only <p>changed resistance table for 2.2K3A1 sensor</p>

Table 1. Revision history

1.2 Safety rules

- **Note:** Incorrect wiring of this product can damage it and lead to other hazards. Make sure the product has been correctly wired before turning the power ON.
- Before wiring, or removing/mounting the product, be sure to turn the power OFF. Failure to do so might result in electric shock.
- Do not touch electrically charged parts, such as the power terminals. Doing so may result in electric shock.
- Do not disassemble the product. Doing so may result in electric shock or faulty operation.
- Use the product within the operating ranges recommended in the specification (temperature, humidity, voltage, shock, mounting direction, atmosphere etc.). Failure to do so might result in fire or faulty operation
- Tighten the wires firmly to the terminal. Insufficient tightening of the wires to the terminal might cause fire.

1.3 Technical specifications

Power supply	Voltage	24 V AC/DC \pm 20%	
	Power consumption		
	Module type	@ 24 VDC	@ 24 VAC
	8I	0.4 W	0.6 VA
	8I-IP	1.4 W	2.1 VA
	8U	0.5 W	0.8 VA
	8U-IP	1.5 W	2.3 VA
	4I40-H	1.2 W	1.8 VA
	4I40-H-IP	2.2 W	3.3 VA
	4U40-H	1.2 W	1.8 VA
	4U40-H-IP	2.2 W	3.3 VA
	4U4A-H	2.2 W	3.3 VA
	4U4A-H-IP	3.2 W	4.8 VA
	4O-H	1.6 W	2.4 VA
	4O-H-IP	2.6 W	3.9 VA
	4TO-H	1.0 W	1.5 VA
	4TO-H-IP	2.0 W	3.0 VA
	MIX18	3.0 W	4.5 VA
	MIX18-IP	4.4 W	6.6 VA
	MIX38	5.0 W	7.5 VA
MIX38-IP	7.4 W	11.1 VA	
Universal Inputs	Temperature input	<ul style="list-style-type: none"> • Measurement with RTDs attached • Accuracy $\pm 0.1^{\circ}\text{C}$ • For Pt1000 and Ni1000 sensors use 16-bit resolution 	
	Voltage input	<ul style="list-style-type: none"> • Voltage measurement from 0 - 10 V • Input impedance 100 kΩ • Measurement accuracy $\pm 0.1\%$ • Measurement resolution 3 mV@12-bit and 1 mV@ 16-bit 	
	Current input	<ul style="list-style-type: none"> • Current measurement 0 - 20 mA • Required external resistor 200 Ω • Measurement accuracy $\pm 1.1\%$ • Measurement resolution 15 μA @ 12-bit and 5 μA @ 16-bit 	
	Resistive input	<ul style="list-style-type: none"> • Measurement of resistance from 0 to 1000 kΩ • Measurement resolution for 20 kΩ load 20 Ω@12-bit and 1 Ω@16-bit 	

		<ul style="list-style-type: none"> Measurement resolution for PT1000 and NI1000 0.1Ω@16bit
	Resistance measurement method	Voltage divider
	Dry contact input	Output current ~1 mA
	Measurement resolution	12-bits (default) or 16-bits
	Processing time	<ul style="list-style-type: none"> 10 ms/channel at 12-bits 140 ms/channel at 16-bits
Digital Inputs	Type	Dry contact
	Max input frequency	100 Hz
Analog Outputs	Voltage range	0 to 10 V
	Max. load current	20 mA
	Resolution	12-bits
	Accuracy	±0.5%
Digital Outputs (relays)	Contact material	AgSnO2
	Resistive load AC1	3 A @ 230 VAC or 3 A @ 30 VDC
	Inductive load AC3	75 VA @ 230 VAC or 30 W @ 30 VDC
	Capacitive load	<ul style="list-style-type: none"> 50 W @ LED + PS 230 VAC 100 W @ fluorescent lamps with electronic ballast 75 W @ CFL Compact fluorescent lamp
Digital Outputs (relays) 40-H and 40-H-IP	Contact material	AgSnO2
	Resistive load AC1	8 A @ 230 VAC or 8 A @ 30 VDC
	Inductive load AC3	360 VA @ 230 VAC or 90 W @ 30 VDC
	Capacitive load	<ul style="list-style-type: none"> 120 W @ LED + PS 230 VAC 240 W @ fluorescent lamps with electronic ballast 180 W @ CFL Compact fluorescent lamp
Triac Outputs	Continuous load per channel	0.5 A @ 20 VAC up to max. 250 VAC
	Peak load per channel	1.5 A @ 20 VAC up to max. 250 VAC (30 s)
	Gate Control	Zero crossing turn ON
	Frequency Range	47 to 63 Hz
	Snubber	Snubberless Triac
RS485 Interface	RS485	Up to 128 devices
	Communication protocols	Modbus RTU, Modbus ASCII or BACnet set by switch
	Baud rate	From 2400 to 115200 set by switch
	Address	0 to 99 set by switch
Ethernet	MIX18-IP, MIX38-IP	
	2x Fast Ethernet	Switch mode

USB	Baud rate	10/100 Mb/s	
	8I-IP, 8U-IP, 4I40-H-IP, 4U40-H-IP, 4U4A-H-IP, 4O-H-IP, TO-H-IP		
	1x Fast Ethernet	IP Interface	
	Baud rate	10/100 Mb/s	
	USB	Mini USB 2.0	
	Ingress protection	IP	IP40
	Temperature	Storage	-40°C to +85°C
		Operating	-10°C to +50°C
	Humidity	Relative	5% to 95%
	Connectors	Type	Removable
		Maximum cable size	2.5 mm ²
		Maximum tightening torque	0,35 Nm
	Dimensions	MIX18, MIX18-IP	
Width		110 mm	
Length		88 mm	
Height		62 mm	
MIX38, MIX38-IP			
Width		110 mm	
Length		160 mm	
Height		62 mm	
MINI Series			
Width		110 mm	
Length		37 mm	
Height		62 mm	

Table 1 Technical specifications

1.4 Summary table for all modules

Module type	UI	DI	AO	DO	TO	Modbus RS485	Modbus TCP/IP	BACnet MSTP	BACnet IP
4I40-H		4		4		✓		✓	
4I40-H-IP		4		4		✓	✓		✓
4O-H				4 (NC/NO-8A)		✓		✓	
4O-H-IP				4 (NC/NO-8A)		✓	✓		✓
4U4A-H	4		4			✓		✓	
4U4A-H-IP	4		4			✓	✓		✓
4U40-H	4			4		✓		✓	
4U40-H-IP	4			4		✓	✓		✓

8I		8				✓		✓	
8I-IP		8				✓	✓		✓
8U	8					✓		✓	
8U-IP	8					✓	✓		✓
4TO-H					4	✓	✓		✓
4TO-H-IP					4	✓	✓		✓
MIX18	5	5	4	4		✓		✓	
MIX18-IP	5	5	4	4		✓	✓		✓
MIX38	8	12	6	12		✓		✓	
MIX38-IP	8	12	6	12		✓	✓		✓
						RTU ASCII	Modbus Gateway IP/RS485	Master Slave	

Table 2. Summary table for all modules

1.5 Dimensions

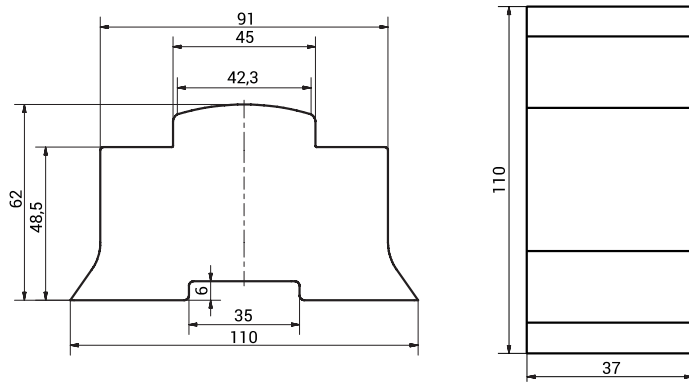

Figure 1. MINI series dimensions

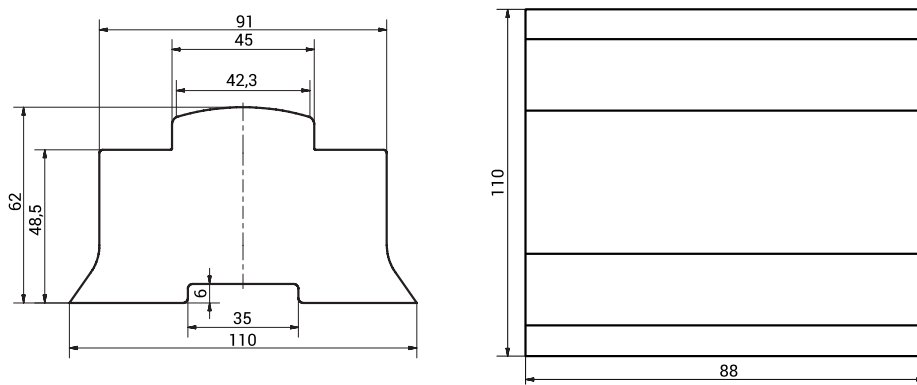

Figure 2. MIX18 and MIX18-IP dimensions

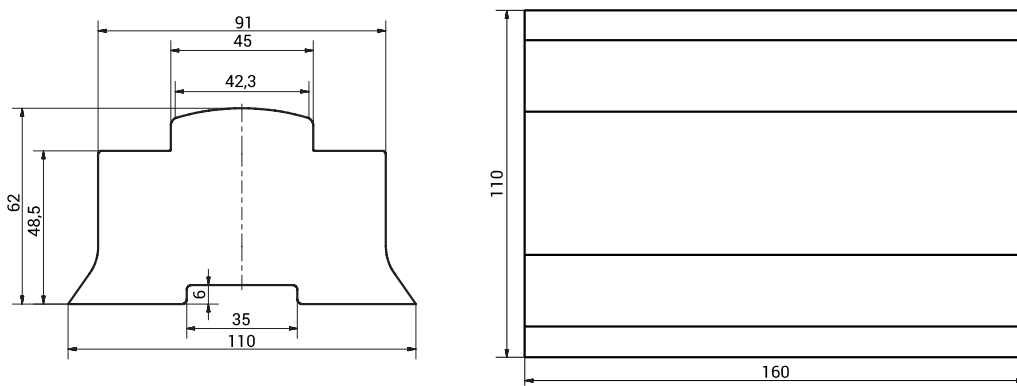

Figure 3. MIX38 and MIX38-IP dimensions

1.6 Power supply connection

1.6.1 DC power connection

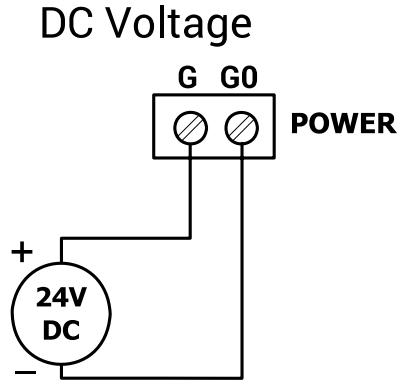

Figure 4. DC power supply connection

1.6.2 AC power connection

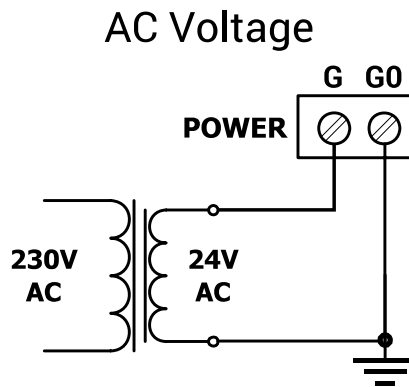

Figure 5. AC power supply connection

1.7 Connecting the communication bus (RS485)

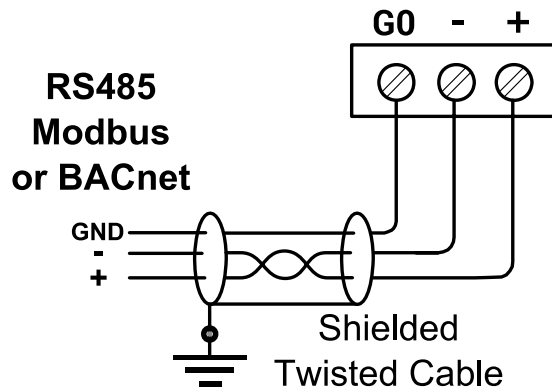

Figure 6. RS485 connection

1.8 LED Indicators

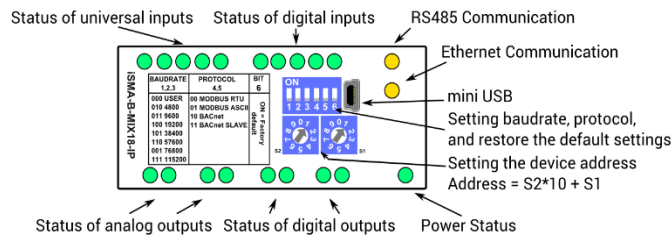

Figure 7. Top panel MIX18-IP

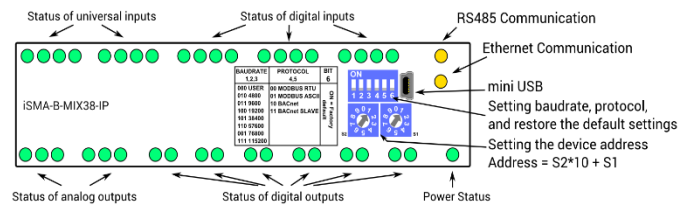

Figure 8. Top panel MIX38-IP

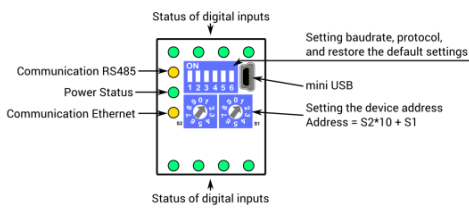

Figure 9. Top panels 8I and 8I-IP

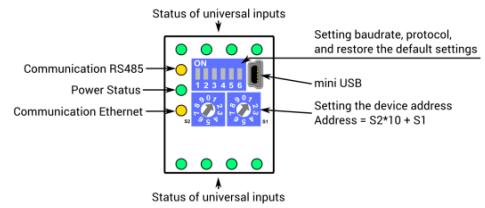

Figure 10. Top panels 8U and 8U-IP

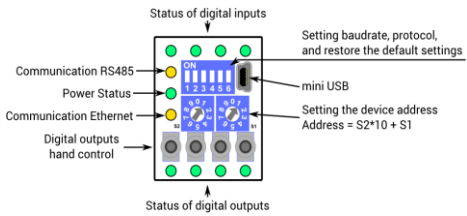

Figure 11. Top panels 4I40-H and 4I40-H-IP

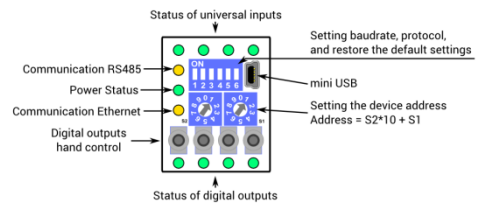

Figure 12. Top panels 4U40-H and 4U40-H-IP

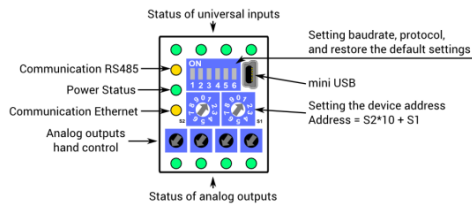

Figure 13. Top panels 4U4A-H and 4U4A-H-IP

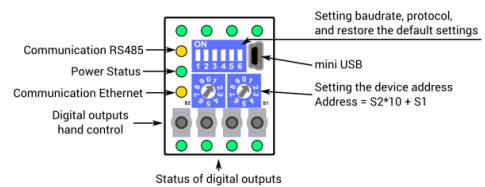

Figure 14. Top panels 40-H and 40-H-IP

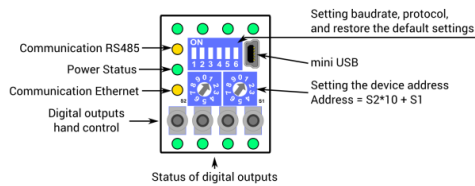

Figure 15. Top panels 4TO-H and 4TO-H-IP

- The power LED is ON (green) when the module runs properly.
- Communication LED is ON (orange) for 20 ms after sending each message. If the module receives/sends a lot of messages, LED can be lit continuously.
- LEDs indicating the status of the Universal Inputs are lit when the resistance connected to the input is less than 5 k Ω (Dry Contact input is active).

WARNING! The LED also lights up when the voltage connected to the input has a very low potential.

- LEDs indicating the status of the digital inputs are lit when the input is active.
- LEDs indicating the status of the analog outputs are lit when the output voltage or PWM factor is different from 0.
- LEDs indicating the status of the digital outputs are lit when the output is enabled.

1.9 Grounding and shielding

In most cases, IO modules will be installed in an enclosure along with other devices which generate electromagnetic radiation. Relays, contactors, transformers, motor invertors etc. are the examples of these devices. Radiation can induce electrical noise into both power and signal lines, as well as direct radiation into the module causing negative effects for the system. Appropriate grounding, shielding and other protective steps should be taken at the installation stage to prevent these effects. These protective steps include control cabinet grounding, cable shield grounding, using protective elements for electromagnetic switching devices, correct wiring, and choosing the cables of proper type and cross-section.

1.10 RS485 network termination

Transmission line effects often present a problem in data communication networks. These problems include reflections and signal attenuation.

To eliminate the presence of reflections from the end of the cable, it must be terminated at both ends with a resistor across the line, in accordance with its characteristic impedance. Both ends must be terminated since the direction of propagation is bidirectional. In case of an RS485 twisted pair cable this termination is typically 120 Ω .

1.11 Setting module address on Modbus network

To determine the address on the Modbus network, the module is equipped with two rotary switches, S1 and S2, located on the top panel of the device.

It is possible to set the device address from 0 to 99.

The address is set with the following formula:

$$\text{Address} = \text{S2} \cdot 10 + \text{S1}$$

where S1 and S2 are the values of the switches.

For example:

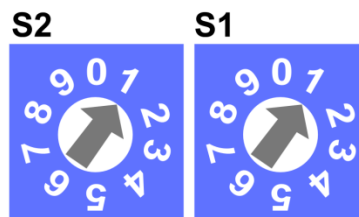

Figure 16. Exemplary address setting

Switches set as in figure above will set the module address to 11.

1.12 Baud rate selection

Transmission baud rate is set with S3 switch (sections 1, 2 and 3) in accordance with the following table:

1	2	3	Baud rate
OFF (0)	OFF (0)	OFF (0)	Defined by the user in the registry
OFF (0)	OFF (0)	ON (1)	76800
OFF (0)	ON (1)	OFF (0)	4800
OFF (0)	ON (1)	ON (1)	9600
ON (1)	OFF (0)	OFF (0)	19200
ON (1)	OFF (0)	ON (1)	38400
ON (1)	ON (1)	OFF (0)	57600
ON (1)	ON (1)	ON (1)	115200 (factory set)

Table 3. Baud rate selection

1.13 Protocol selection

The protocol is selected with sections 4 and 5 of the S3 switch according to table below:

4	5	Protocol
<i>OFF (0)</i>	<i>OFF (0)</i>	<i>Modbus RTU</i>
<i>OFF (0)</i>	<i>ON (1)</i>	<i>Modbus ASCII</i>
<i>ON (1)</i>	<i>OFF (0)</i>	<i>BACnet Master</i>
<i>ON (1)</i>	<i>ON (1)</i>	<i>BACnet Slave</i>

Table 4. Protocol selection

1.14 Restoring the default settings

To restore the default configuration of all registers, follow the steps below:

1. Turn off the power supply;
2. Set section 6 of S3 switch to ON;
3. Turn on the power supply; power LED blinks;
4. Switch section 6 of S3 switch to OFF to restore the default settings. To cancel the reset, turn off the power and switch section 6 of S3 switch to the OFF position.

1.15 Default Settings

In its out-of-the-box state, as well as after restoring the default values, the device has got the following default register values:

Register Name	Default Value
<i>COUNTER</i>	<i>0</i>
<i>BAUD RATE</i>	<i>76800 (76800 bps)</i>
<i>STOP BITS</i>	<i>1</i>
<i>DATA BITS</i>	<i>8</i>
<i>PARITY BITS</i>	<i>0</i>
<i>RESPONSE DELAY</i>	<i>0</i>
<i>WATCHDOG TIME</i>	<i>0 (disabled)</i>
<i>STATE OF THE DIGITAL OUTPUTS AFTER START</i>	<i>0</i>
<i>STATE OF THE ANALOG OUTPUTS (DIGITAL) AFTER START</i>	<i>0</i>
<i>STATE OF THE ANALOG OUTPUTS AFTER START</i>	<i>0</i>
<i>UNIVERSAL INPUT CONFIGURATION</i>	<i>1</i>
<i>INPUT FILTER TIME CONSTANT</i>	<i>2</i>
<i>UNIVERSAL INPUT RESOLUTION</i>	<i>0</i>
<i>ANALOG OUTPUT CONFIGURATION</i>	<i>0</i>
Only for modules with IP	
<i>USERNAME</i>	<i>Platform</i>
<i>PASSWORD</i>	<i>1000</i>
<i>IP ADDRESS</i>	<i>192.168.1.123</i>
<i>MASK</i>	<i>255.255.255.0</i>
<i>GATEWAY</i>	<i>192.168.1.1</i>
<i>HTTP PORT</i>	<i>80</i>
<i>MODBUS TCP PORT</i>	<i>502</i>
<i>MODBUS TCP TIMEOUT</i>	<i>60s</i>
<i>RS485 TIMEOUT</i>	<i>1000ms</i>
<i>SEND MODBUS ERRORS</i>	<i>DISABLED</i>
<i>BACNET ID</i>	<i>826001</i>
<i>BACNET UDP PORT</i>	<i>47808 (0xBAC0)</i>

Table 5. Default values

2 Configuration registers

WARNING! Changing the parameters concerning the configuration of the transmission will only take effect after restarting the unit (except for the registers the value of which is read from the switch).

2.1 Firmware version and module type (30001)

In this register type and firmware version of module are encoded.

Low byte contains information about the type of module in accordance with the table below:

Value	Type
81_{10} ($0x51_{16}$)	8I
91_{10} ($0x5B_{16}$)	8I-IP
84_{10} ($0x54_{16}$)	8U
94_{10} ($0x5E_{16}$)	8U-IP
83_{10} ($0x53_{16}$)	4I40-H
93_{10} ($0x5D_{16}$)	4I40-H-IP
85_{10} ($0x55_{16}$)	4U40-H
95_{10} ($0x5F_{16}$)	4U40-H-IP
86_{10} ($0x56_{16}$)	4U4A-H
96_{10} ($0x60_{16}$)	4U4A-H-IP
82_{10} ($0x52_{16}$)	4O-H
92_{10} ($0x5C_{16}$)	4O-H-IP
87_{10} ($0x57_{16}$)	4TO-H
97_{10} ($0x61_{16}$)	4TO-H-IP
50_{10} ($0x32_{16}$)	MIX18
51_{10} ($0x33_{16}$)	MIX38
52_{10} ($0x34_{16}$)	MIX18-IP
53_{10} ($0x35_{16}$)	MIX38-IP

Table 6. Firmware version and module type

The high byte contains the module firmware version multiplied by 10.

For example:

In 30001 register, number $12810_{10} = 0x320A_{16}$, which means that it is module MIX18 ($0x32$) with firmware in version 1.0 ($0x0A_{16} = 10_{10}$).

2.2 Module address (30002)

This register contains information about the address of the Modbus module. This address is set with switches S1 and S2 (see section Setting module address on Modbus).

2.3 Baud rate and protocol (30003)

The register contains information about the baud rate and type of protocol in accordance with the table below. This register reflects the state of S3 switch.

Baud rate			Protocol			
Bit 0	Bit 1	Bit 2	Baud rate	Bit 3	Bit 4	Protocol
0	0	0	User defined	0	0	Modbus RTU
0	0	1	76800	0	1	Modbus ASCII
0	1	0	4800	1	0	BACnet Master
0	1	1	9600	1	1	BACnet Slave
1	0	0	19200			
1	0	1	38400			
1	1	0	57600			
1	1	1	115200			

Table 7. Baud rate and protocol

2.4 Counter of received messages (30004)

32-bit register with the number of valid Modbus messages received by the module which was powered up last. The value is reset after the power cycle or after changing transmission parameters (speed, stop bits, parity, etc.).

2.5 Counter of error messages (30006)

32-bit register with the number of error Modbus messages received by the module which was powered up last. The value is reset after the power cycle or after changing transmission parameters (speed, stop bits, parity, etc.).

2.6 Counter of sent messages (30008)

32-bit register with the number of error Modbus messages received by the module which was powered up last. The value is reset after the power cycle or after changing transmission parameters (speed, stop bits, parity, etc.).

2.7 Up time (30012)

This 16-bits register contains module counting time in seconds from the last powering up or module reset.

2.8 Hardware_version (30130)

This 16-bits register contains the module hardware version multiplied by 10.

2.9 MAC_address (30131)

This 32-bits register contains MAC address information of the module.

2.10 Device actions (40001)

Setting register 40001 according to the table below will enable 1 of 4 available actions: module reset, reloading the settings, setting to default and entering the bootloader.

Value	Action
511	Reset
767	Reload settings
1023	Set to default
1279	Enter Bootloader

Table 8. Device actions

2.11 Baud rate (40136)

When sections 1, 2 and 3 of S3 switch are in off position, baud rate is determined in accordance with this register. Baud rate is determined with the following formula:

$$\text{Baud rate} = \text{register value} \cdot 10$$

2.12 Stop bits (40137)

Number of the stop bits is determined on the basis of this register in accordance with the following table:

Value	No. of stop bits
1 (default)	1
2	2
256	RS485 biasing*

Table 9. Stop bits

*Bit No. 8 activates RS485 biasing resistors in order to pull-up the voltage on RS485 bus. When bit No. 8 is true (bit 8 = 1), RS485 biasing resistors are activated. The function is **only** available in **MINI modules** with hardware version ≥ 2.0

The biasing resistors are useful in case when iSMA modules are connected with third party devices with the same RS485 bus and communication errors appear on the network.

WARNING! Only a single device in the network can have biasing resistors activated!

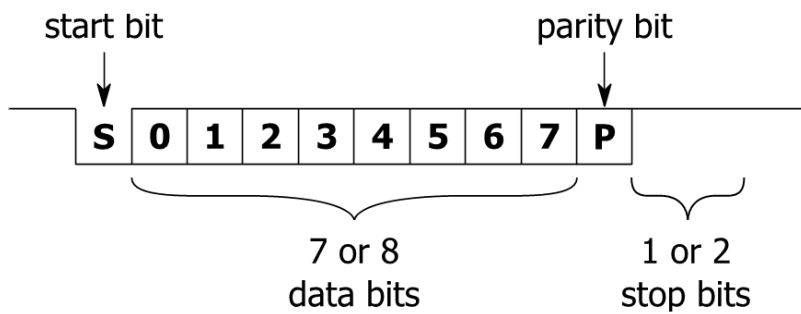

Figure 17. Modbus message frame

2.13 Data bits (40138)

Number of data bits transmitted in a single byte is determined according to the following table:

Value	No. of data bits
7	7
8 (default)	8

Table 10. Data bits

2.14 Parity bit (40139)

Every byte of data being transferred may have an additional protection in the form of a parity bit added before the stop bit (bits).

The method of calculating the parity bit is presented in the table below:

Register value	Type of parity bit
0 (default)	none
1	Odd (number of all ones in a byte is odd)
2	Even (number of all ones in a byte is even)
3	Always 1
4	Always 0

Table 11. Parity bit

2.15 Response delay time (40140)

The value of this 16-bit register determines the number of milliseconds to wait before the unit answers the question. This time is used to extend the interval between the question and answer. The default value of 0 means no delay (the answer is sent once during the transmission of 3.5 character required by the protocol Modbus RTU).

2.16 Watchdog time (40141)

This 16-bit register specifies the time in seconds to watchdog reset. If the module does

not receive any valid message within that time, all Digital and Analog Outputs will be set to default state.

This feature is useful if for some reason there is an interruption in data transmission and for security reasons the output states must be set to the appropriate state in order not to endanger the safety of persons or property.

The default value is 0 seconds which means the watchdog function is disabled.

When the watchdog is triggered, Power LED blinks in the specified sequence (3 blinks with 20Hz frequency and 1 second pause).

3 Local I/O

3.1 Universal Inputs connections

3.1.1 Connection of Universal Input to measure voltage 0 – 10V

Voltage measurement

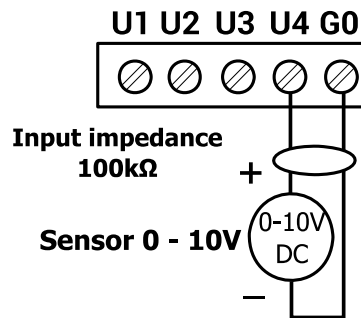

Figure 18. Connection of UI to measure 0-10 VDC for MIX38 and MIX38-IP

3.1.2 Connection of the Universal Input to measure current 0 – 20 mA

Current measurement is performed by measuring the voltage and 200 Ω resistance. According to Ohm's law, the current is directly proportional to the voltage and the resistance as the constant of proportionality.

$$I = \frac{U}{R}$$

According to the Ohm's law equation, for 20mA current with 200Ω resistance the output voltage is 4V, which means that the voltage of 4V on the Universal Input corresponds with 20mA current.

The result is expressed in millivolts.

Current measurement

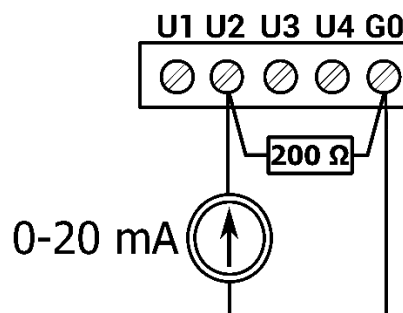

Figure 19. Connection of UI to measure 0-20mA for MIX38 and MIX38-IP

3.1.3 Connection of Universal Input to measure the temperature

Temp. measurement

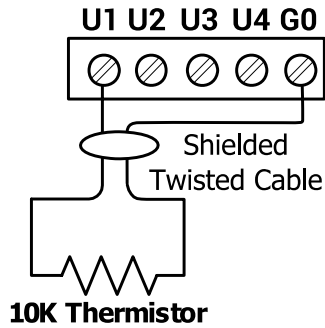

Figure 20. Connection of UI to measure the temperature for MIX18 and MIX18-IP

3.1.4 Connection of Universal Input as a Digital Input (Dry Contact)

Dry Contact Input

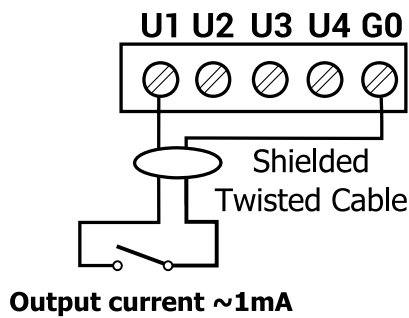

Figure 21. Connection of UI for operating as DI for MIX38 and MIX38-IP

3.2 Universal Inputs MODBUS Registers

3.2.1 Status of Universal Inputs working as Digital Inputs (30017)

This 16-bit register contains information about the status of Digital Inputs (dry contacts). When the input is shortcut to the ground, the corresponding bit value is set to 1 in accordance with the following table:

No. of bit in register	No. of Universal Input
0	1
1	2
2	3
3	4
4	5
5	6
6	7
7	8

Table 12. UI register operating as DI for MIX38 and MIX38-IP

3.2.2 Universal Input voltage (current) measure 1 - 8 (30071, 30073, 30075, 30077, 30079, 30087, 30089, 30091)

These 16-bit registers contain the results of measuring the voltage for each input. The result is expressed in millivolts.

The results of measuring the current for each input are stored in the same registers. In that case the current value has to be calculated according to the equation:

$$I = \frac{\text{register value}}{200} \text{ [mA]}$$

3.2.3 Universal Input temperature measurement 1 - 8 (30072, 30074, 30076, 30078, 30080, 30095, 30097, 30099)

In these 16-bit registers the result is expressed in Celsius degrees • 10

3.2.4 Universal Input resistance measurement 1 - 8 (30103, 30104 – 30117, 30118)

In these 16-bit registers the result is expressed in Ω or in 0.1Ω units for PT1000 and NI1000 configuration. In the register with lower number it is the lower storage part of the result and the higher register storage part of the result.

3.2.5 Universal Input configuration 1 - 8 (40151 – 40158)

These 16-bit registers are used to configure Universal Inputs in accordance with the following table:

Register value	Description
0	Off resistance measurement (only measuring the voltage, dry contact off)
1 (default)	Temperature sensor 10K3A1 NTC B=3975K
2	Temperature sensor 10K4A1 NTC B=3695K
3	Temperature sensor 10K NTC B=3435K Carel
4	Temperature sensor 20K6A1 NTC B=4262K
5	Temperature sensor 2,2K3A1 NTC B=3975K
6	Temperature sensor 3K3A1 NTC B=3975K
7	Temperature sensor 30K6A1 NTC B=4262K
8	Temperature sensor SIE1
9	Temperature sensor TAC1
10	Temperature sensor SAT1
16	Temperature sensor Pt1000
17	Temperature sensor Ni1000
+128 (set 7. bit of register)	Off voltage measurement

Table 13. Universal input configuration

3.2.6 Filter time constant of the Universal Input 1 - 8 (40159 – 40166)

These 16-bit registers contain a time constant low pass filter. The value is expressed in seconds. Valid values must be between 0 and 60 seconds. The default filter value is 2 seconds. Setting the value to 0 will disable the filter.

In case of UI shortcut or open-loop the filter is reset and UI value filtering is stopped.

3.2.7 Resolution of the Universal Inputs (40167)

This register is used to determine the bit resolution for each of the Universal Inputs.

Setting the bit to 0 will set the resolution of the converter to 12-bit. Setting the bit to 1 sets the resolution of the converter to 16-bit.

WARNING! Setting 16-bit resolution increases the measurement time of one channel from 10ms to 140ms. The total time taken to measure all the channels increases from 50ms to 700ms.

Each input can be configured separately in accordance with the following table:

No. of bit in register	No. of Universal Input
0	1
1	2
2	3
3	4

4	5
5	6
6	7
7	8

Table 14. Universal input resolution for MIX38 and MIX38-IP

3.3 Digital Inputs Connections

3.3.1 Connection of Digital Input (Dry Contact)

Dry Contact Input

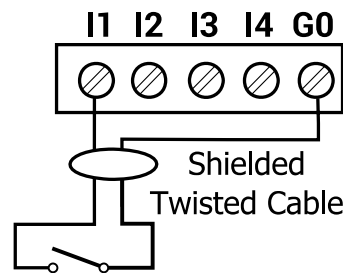

Output current ~1mA

Figure 22. Connection of DI for MIX38 and MIX38-IP

3.4 Digital Input MODBUS Registers

3.4.1 State of Digital Inputs (30016)

This 16-bit register contains the status of the Digital Inputs. Short-circuit input to GND sets the corresponding bit in the register in accordance with the table below:

No. of bit in the register	No. of Digital Input
0	1
1	2
...	...
10	11
11	12

Table 15. Status of DI for MIX38 and MIX38-IP

3.4.2 Counter 1 – 12 (40023, 40024 – 40045, 40046)

The modules have 32-bit counters, one for each Digital Input.

The register with a lower number contains a lower byte of the counter and in the register with a higher number is stored in the higher byte of the counter.

In case you would like to change the value of the register, you can write any value (called 'preset') for pulse counting registers. In a particular case you can reset the counter by entering 0. Resetting the counter is also possible via 40022 registry.

3.4.3 Resetting the counters (40022)

Setting a true value of a particular bit of this 16-bit register results in resetting the corresponding counter (setting it to 0) in accordance with the following table:

No. of bit in the register	No. of Digital Input
0	1
1	2
...	...
10	11
11	12

Table 16. Resetting the counters for MIX38 and MIX38-IP

Setting a true value of a particular bit of the register continuously resets the counter. Setting the bit to 0 restores normal operation.

3.5 Analog Output Connections

3.5.1 Connection of 0-10V Analog Output

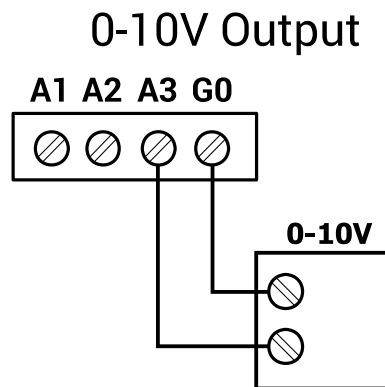

Figure 23. Connection of AO for MIX38 and MIX38-IP

3.5.2 Connecting relay to Analog Output

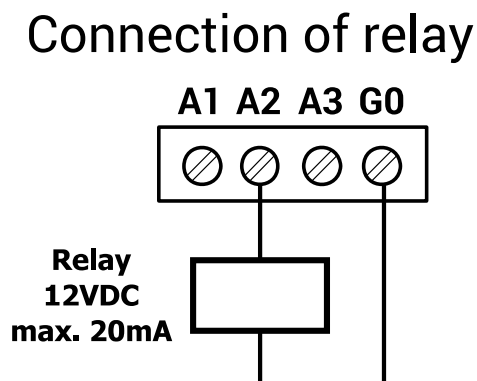

Figure 24. Connection of AO to the relay for MIX38 and MIX38-IP

3.5.3 Connecting an actuator to the Analog Output

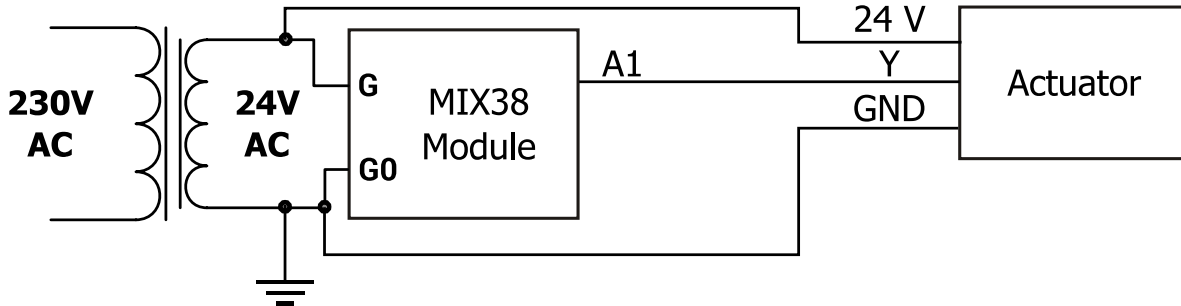

Figure 25. Connecting an actuator to AO

3.6 Analog Output MODBUS Registers

3.6.1 State of Analog Outputs operating as Digital Outputs (40019)

Setting a true value of a particular bit of this 16-bit register causes setting the maximum output voltage (10V) on the corresponding output and setting the corresponding register with Analog Output value (40121 – 40126) to 0.

Bits of register correspond to the following Analog Outputs.

No. of bit in the register	No. of Analog Output
0	1
1	2
2	3
3	4
4	5
5	6

Table 17. AO operating as DO for MIX38 and MIX38-IP

3.6.2 Value of 1-6 Analog Outputs (40121 – 40126)

These 16-bit registers contain the value of voltage in mV that appears at the Analog Output.

3.6.3 Default state of the Analog Outputs (digital) (40144)

Setting a true value of a particular bit of this 16-bits register sets the maximum voltage (10V) on the corresponding Analog Output after turning the power on or resetting the

watchdog.

Bits in register correspond to the following Analog Outputs:

No. of bit in the register	No. of Analog Output
0	1
1	2
2	3
3	4
4	5
5	6

Table 18. Default state of AO operating as DO for MIX38 and MIX38-IP

3.6.4 Default state of 1-6 Analog Outputs (40145 – 40150)

These 16-bit registers contain the values of voltage in mV which appear on the Analog Outputs after turning the power on or resetting the watchdog.

3.6.5 Configuration mode of 1-6 Analog Outputs (40168 – 40173)

These 16-bit registers contain information about the mode of the Analog Outputs according to following table:

Register value	Description
0 (default)	Voltage output 0 – 10V
1	PWM 1Hz
2	PWM 10Hz
3	PWM 100Hz
4	PWM 0.1Hz
5	PWM 0.01Hz

Table 19. AO type settings

3.6.6 Hand control status of analog outputs (30015)

This register is available only for the modules with manual control of Analog Outputs.

No. of bit in register	Description
------------------------	-------------

<i>0, 1</i>	<i>Hand status of outputs 1</i>
<i>2, 3</i>	<i>Hand status of outputs 2</i>
<i>4, 5</i>	<i>Hand status of outputs 3</i>
<i>6, 7</i>	<i>Hand status of outputs 4</i>

Table 20. AO Hand status bits

Value of the hand status	Status Description
<i>0</i>	<i>AUTO</i>
<i>1</i>	<i>HAND CONTROL</i>

Table 21. AO hand status value

The current value of the output in the hand mode determines registers from 30125 to 30128.

3.6.7 Hand control value of 1-4 Analog Outputs (30125 - 20128)

The registers contain a percentage value of manual control for outputs from 1 to 4.

3.7 Digital Output (relay) Connections

3.7.1 Connecting the solenoid valve to the Digital Output

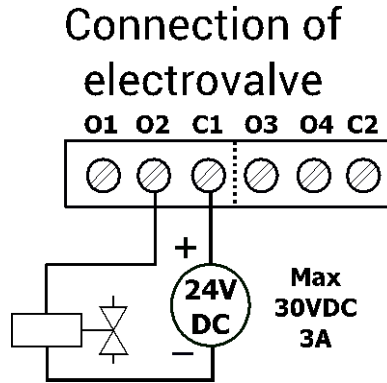

Figure 26. Connection of solenoid valve to DO for MIX38 and MIX38-IP

3.7.2 Connecting a resistive load to the Digital Output

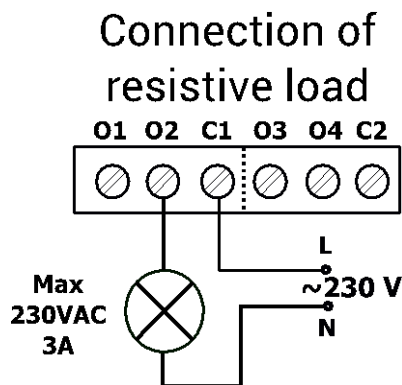

Figure 27. Connection of resistive load to DO for MIX38 and MIX38-IP

3.7.3 Connecting an inductive load to the Digital Output

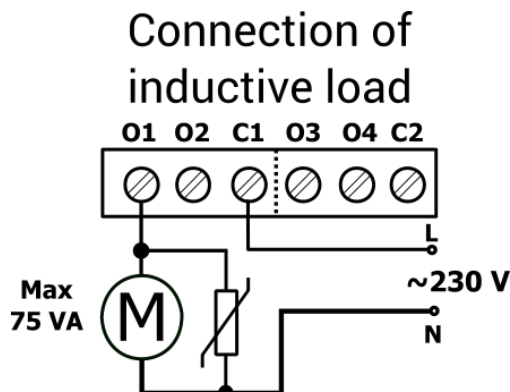

Figure 28. Connection of inductive load to DO for MIX38 and MIX38-IP

3.8 Digital Output (relay) MODBUS Registers

3.8.1 State of Digital Outputs (40018)

This 16-bit register contains the state of the Digital Outputs. Setting a particular bit in the register activates the corresponding Digital Output according to the following table:

No. of bit in register	No. of Digital Output
0	1
1	2
2	3
3	4
4	5
5	6

Table 22. State of DO for MIX38 and MIX38-IP

3.8.2 Default state of Digital Outputs (40143)

This 16-bit register contains the default state of the Digital Output device after the start or watchdog reset. Register bits correspond to the Digital Outputs according to the following table:

No. of bit in the register	No. of Digital Output
0	1
1	2
2	3
3	4
4	5
5	6

Table 23. Default status of DO for MIX38 and MIX38-IP

3.8.3 Hand control status of Digital Outputs (30015)

This register is available only for the modules with manual control of outputs.

No. of bit in the register	Description
0, 1	Hand status of output 1
2, 3	Hand status of output 2
4, 5	Hand status of output 3

6, 7	Hand status of output 4
------	-------------------------

Table 24. DO hand status bits

Value of hand status	Status Description
0	AUTO
2	HAND OUT = 0
3	HAND OUT = 1

Table 25. DO Hand status value

3.9 Triac Output Connections

3.9.1 Connecting the solenoid valve to the Triac Output

Connection of electrovalve

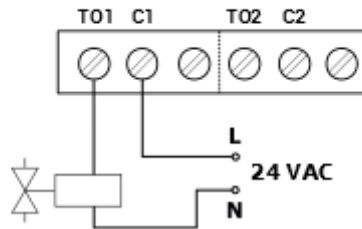

Figure 28. Connection of solenoid valve to T0 for 4TO-H and 4TO-H-IP

3.9.2 Connecting a resistive load to the Triac Output

Connection of resistive load

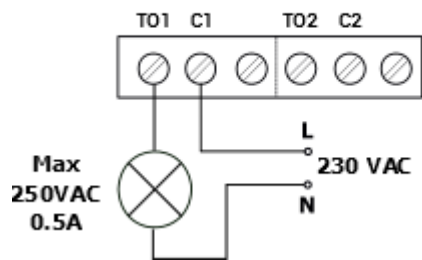

Figure 29. Connection of resistive load to T0 for 4TO-H and 4TO-H-IP

3.10 Triac Output MODBUS Registers

3.10.1 State of Triac Outputs (40018)

This 16-bit register contains the state of the Triac Outputs in digital mode. Setting a particular bit in the register activates the corresponding Triac Output according to the following table:

No. of bit in the register	No. of Triac Output
0	1
1	2
2	3
3	4

Table 26. State of TO for 4TO-H and 4TO-H-IP

3.10.2 Default state of Triac Outputs (40143)

This 16-bit register contains the default state of the Triac Output device after the start or after resetting the watchdog.

The register bits correspond with the Triac Outputs according to the following table:

No. of bit in the register	No. of Digital Output
0	1
1	2
2	3
3	4

Table 27. Default status of TO for 4TO-H and 4TO-H-IP

3.10.3 Value of 1-4 Triac PWM Outputs (40121 – 40124)

These 16-bit registers contain the in percents of the duty that appears on the PWM output. Output working mode is defined by CONFIGURATION mode of the Triac Output.

3.10.4 Default state of 1-4 Triac PWM Outputs (40145 – 40148)

These 16-bit registers contain value in percents of the duty that appears on the Analog Output after turning the power on or resetting the watchdog.

3.10.5 Configuration mode of 1-4 Triac Outputs (40168 – 40171)

These 16-bit registers contain information about the mode of the Triac Outputs according

to the following table:

Register value	Description
1 (default)	Digital Output
2	PWM 1Hz
3	PWM 10Hz
4	Not supported
5	PWM 0.1 HZ
6	PWM 0.01Hz

Table 28 TO type settings

3.10.6 Hand control status of the Triac Outputs (30015)

This register is available only for the modules with manual control of outputs.

No. of bit in the register	Description
0,1	Hand status of outputs 1
2,3	Hand status of outputs 2
4,5	Hand status of outputs 3
6,7	Hand status of outputs 4

Table 29. TO Hand status bits

Value of Hand status	Status Description
0	AUTO
2	HAND OUT = 0
3	HAND OUT = 1

Table 30. TO Hand status value

3.11 Special application modes for 4I40-H, 4I40-H-IP, 4U40-H, and 4U40-H-IP

In 4I40-H, 4I40-H-IP, 4U40-H, and 4U40-H-IP module, simple applications have been in-built which can be used to control building devices. The applications create a logic between the signal from Digital Input and control Digital Output state. The relation between the Inputs and Outputs is shown in the table below and it cannot be changed.

Digital Input	Digital Output
DI1	DO1
DI2	DO2
DI3	DO3
DI4	DO4

Table 32. Built-in application determining the relation between input and output

The Digital Inputs in modules type 4I40-H, 4I40-H-IP, 4U40-H, and 4U40-H-IP can be set to work in different modes. There are dedicated registers for operation mode (40176, 40180, 40184, 40188), time parameters (40177, 40181, 40185, 40189), setpoints for heating/cooling modes (40178, 40182, 40186, 40190 4U40-H, and 4U40-H-IP only) and for differential value in heating/cooling modes (40179, 40183, 40187, 40191 4U40-H and 4U40-H-IP only).

Register	Description
40176	DI1 OPERATION MODE
40177	DI1 TIME VALUE
40178	DI1 SETPOINT (4U40-H and 4U40-H-IP only)
40179	DI1 DIFFERENTIAL (4U40-H and 4U40-H-IP only)
40180	DI2 OPERATION MODE
40181	DI2 TIME VALUE
40182	DI2 SETPOINT (4U40-H and 4U40-H-IP only)
40183	DI2 DIFFERENTIAL (4U40-H and 4U40-H-IP only)
40184	DI3 OPERATION MODE
40185	DI3 TIME VALUE
40186	DI3 SETPOINT (4U40-H and 4U40-H-IP only)
40187	DI3 DIFFERENTIAL (4U40-H and 4U40-H-IP only)

40188	DIA OPERATION MODE
40189	DIA TIME VALUE
40190	DIA SETPOINT (4U40-H and 4U40-H-IP only)
40191	DIA DIFFERENTIAL (4U40-H and 4U40-H-IP only)

Table 33. List of registers dedicated for special application mode

3.11.1 Operation Mode registers (40176, 40180, 40184, and 40188)

This register contains information about the module working mode. Available modes and register values are shown in the table below:

Value	OPERATION MODE Register
0	Ordinary IO(def)
1	Monostable Relay
2	Bistable Relay
3	Time Relay NO [ms]
4	Time Relay NC [ms]
5	Time Relay NO [s]
6	Time Relay NC [s]
7	Input Forwarding
8	Heating (4U40-H and 4U40-H-IP only)
9	Cooling (4U40-H and 4U40-H-IP only)

Table 34. Special application modes

The operating mode can be changed by writing the right value in the Operation Mode register.

Special modes are initialized after 3 seconds from the power-up or restart of the module (the time value needed to stabilize the operation of the analog transmitter).

With each change of Input Mode change, the assigned Output is set to default state and the timer used in time-based modes is reset. When the recently selected operating mode is running, the output is controlled according to the new mode activated.

3.11.1.1 Ordinary IO

In this mode, the module operates as a standard IO; the inputs and the outputs are not related which each other.

3.11.1.2 Monostable Relay

In this mode, both the rising and the falling edge of the digital input change the output state. The action of a monostable relay can be executed remotely by changing the state

of bit from false to true in COMMAND register (40020). Outputs can be also overwritten with DIGITAL OUTPUT register (40018), which allows remote control from BMS.

3.11.1.3 Bistable Relay

In this mode, only the rising edge of the digital input changes the output state. The action of a bistable relay can be executed remotely by changing the state of bit from false to true in COMMAND register (40020). Outputs can be also overwritten by DIGITAL OUTPUT register (40018), which allows remote control from BMS.

3.11.1.4 Time Relay NO [ms]

In this mode, when the output value is false, the rising edge of the digital input sets the output to a true value. Every falling edge of the digital input starts the counter from the beginning, so that the output will stay in a true value for the time defined in the TIME VALUE register (expressed in milliseconds), counting from the last falling edge of the digital input. The action of the time relay can be executed remotely by changing the state from false to true in relevant COMMAND register (40020). The outputs can be also overwritten with the register of DIGITAL OUTPUT module (40018), which allows for remote control from BMS.

3.11.1.5 Time Relay NC [ms]

In this mode, when the output value is false, the falling edge of the digital input sets the output to a true value. Every rising edge of the digital input starts the counter from the beginning, so that the output will stay in true value for a time defined in TIME VALUE register (expressed in milliseconds), counting from the last rising edge of the digital input. The action of time relay can be executed remotely by changing the state from false to true in the relevant COMMAND register (40020). Outputs can be also overwritten with the register of DIGITAL OUTPUT module (40018), which allows for remote control from BMS.

3.11.1.6 Time Relay NO [s]

In this mode, when the output value is false, the rising edge of the digital input sets the output to a true value. Every falling edge on the digital input starts the counter from the beginning, so that the output will stay in true value for a time defined in TIME VALUE register (expressed in seconds), counting from the last falling edge of the digital input. The action of time relay can be executed remotely by changing the state from false to true in relevant COMMAND register (40020). Outputs can be also overwritten with the register of DIGITAL OUTPUT module (40018), which allows for remote control from BMS.

3.11.1.7 Time Relay NC [s]

In this mode, when the output value is false, the falling edge of the digital input sets the output to a true value. Every rising edge on the digital input starts the counter from the

beginning, so that the output will stay in true value for a time defined in TIME VALUE register (expressed in seconds), counting from the last rising edge of the digital input. The action of time relay can be executed remotely by changing state from false to true in the relevant COMMAND register (40020). Outputs can be also overwritten with the register of DIGITAL OUTPUT module (40018), which allows for remote control from BMS.

3.11.1.8 Input Forwarding

In this mode, any signal from the input is transferred directly to the assigned output without any modifications. The operation of the input forwarding mode can be stopped with Block Input function (see [Block Inputs register](#)).

3.11.1.9 Heating mode (4U40-H and 4U40-H-IP only)

In this mode, the output is controlled as a typical thermostat, based on Setpoint register and Control value (Input value) with differential parameter defined in Differential register. The output signal works in 2 states, low and high.

When the Control value is lower or equal with the difference between the Setpoint register and the differential register, the output is in the low state.

When the Control value is higher or equal with the sum of the Setpoint register and the differential register, the output is in the high state.

Output in the low state:

Control value \geq Setpoint + Differential

Output in the high state:

Control value \leq Setpoint – Differential

The algorithm of the heating mode is shown in chart below.

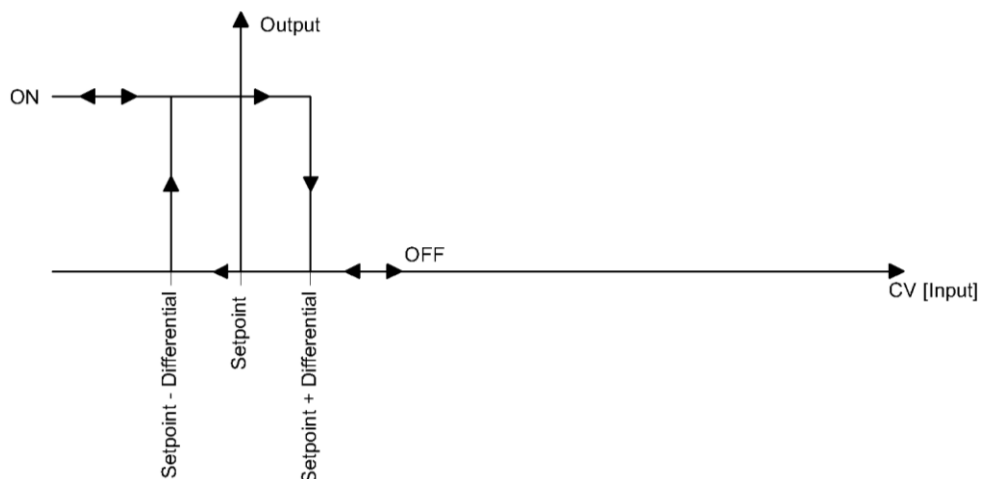

Figure 30. The operation of the Heating mode algorithm

WARNING! In case when the temperature sensor fails (when it is disconnected or shortcut), the heating mode is not active and the output remains in the false state.

3.11.1.10 Cooling mode (4U40-H and 4U40-H-IP only)

In this mode, the output is controlled as a typical thermostat on the basis of the Setpoint register and the Control value (Input signal) with differential parameter defined in the Differential register.

The output signal works in 2 states - low and high.

When the Control value is lower or equal with the difference between the Setpoint register and the Differential register, the output is in the low state.

When the Control value is higher or equal with the sum of the Setpoint register and Differential register, the output is in the high state.

Output in the low state:

Control value \leq Setpoint – Differential

Output in the high state:

Control value \geq Setpoint + Differential

The algorithm of the cooling mode is shown in the chart below.

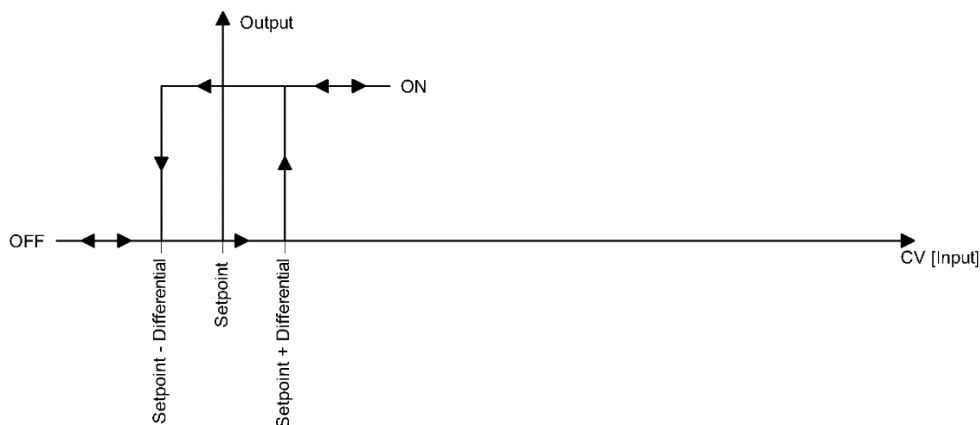

Figure 31. Operation of the cooling mode algorithm

WARNING! In case when the temperature sensor is fails (when it is disconnected or shortcut), the heating mode does not work and the output remains in the false state.

3.11.2 Time Value registers (40177,40181,40185,40189)

The registers contain time values for TIME RELAY modes. The time unit depends on selected mode [milliseconds] or [seconds].

3.11.3 Command register (40020)

The module is equipped with a special register called COMMAND (40020). The command register is used for remotely execute action (simulate light switch/PIR). The action is executed by changing the state of the relevant bit (changing from false to true). All special application modes can be executed except for Input Forwarding, Heating, and Cooling modes.

No. of bit in the register (40020)	Command input number
0	1
1	2
2	3
3	4

Table 31. Command register for special application modes

3.11.4 Block Inputs register (40021)

The Block Inputs register is used to block the physical input signals to take action in logic. By setting a true value on the relevant bit, the module blocks the input and no action will be executed. Setting false value restores normal operation. The block input function does not work when the heating/cooling input mode is set.

No. of bit in the register (40021)	Block input number
0	1
1	2
2	3
3	4

Table 35. Block input register.

3.11.5 Setpoint registers (40178, 40182, 40186, 40190)

The SETPOINT registers contain values which are used in heating/cooling modes (4U40-H and 4U40-H-IP only) as the setpoints for heating/cooling control algorithm

The default Setpoint value is 21. (read more in [Heating mode](#), [Cooling mode](#)).

The register stores the setpoint multiplied by 10.

3.11.6 Differential registers (40179,40183,40187,40191)

The DIFFERENTIAL registers contain values which are used in heating/cooling modes (4U40-H and 4U40-H-IP only) as the differential for heating/cooling control algorithm. Setpoint registers and Differential registers create deadband of the Control values which has no influence on the output.

$$\text{Deadband} = (\text{Setpoint} - \text{Differential}, \text{Setpoint} + \text{Differential})$$

The default Differential value is 1. (read more in [Heating mode](#), [Cooling mode](#)).

The register stores the differential multiplied by 10.

4 WEB Configuration - IP version only

4.1 Web server access

All IP version modules are equipped an in-built web server, which allows for showing the module status and changing the configuration.

To access the web server, open the browser and enter the IP address of the module, default address for new module (default IP address is **192.168.1.123**). Please use the following credentials:

Username: **platform**

Password: **1000** (by default)

4.2 Device page

This page contains information about the device and its technical specification. Basic Information section includes information about the type of the module, its firmware version and uptime. Device Specification includes information about: Power Supply, Input / Output parameters, Interfaces and mechanical parameters.

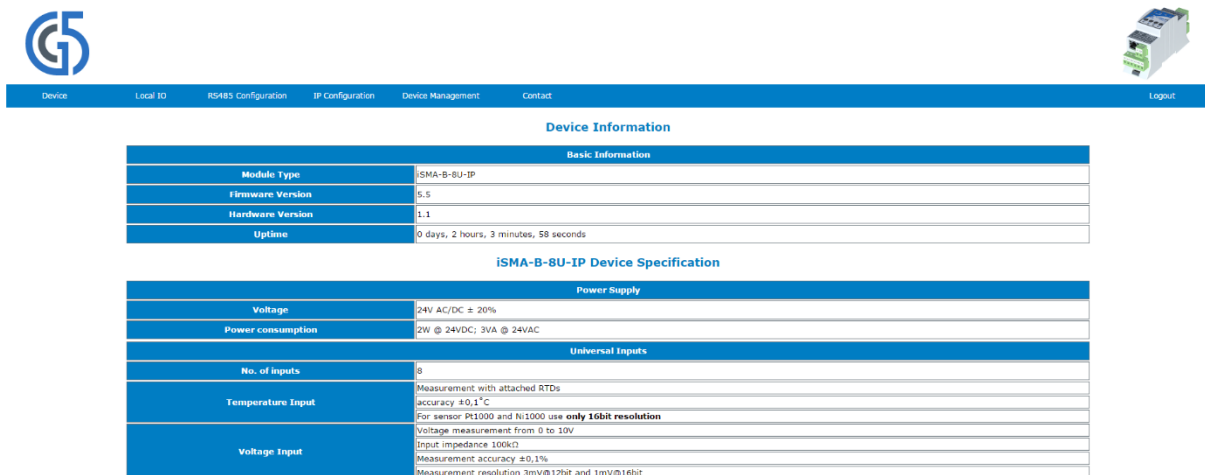

The screenshot shows the web interface for an 8U-IP device. It features a navigation bar with tabs: Device, Local ID, RS485 Configuration, IP Configuration, Device Management, Contact, and Logout. The main content area is titled "Device Information" and is divided into two sections:

Basic Information

Module Type	iSMA-B-8U-IP
Firmware Version	5.5
Hardware Version	1.1
Uptime	0 days, 2 hours, 3 minutes, 58 seconds

iSMA-B-8U-IP Device Specification

Power Supply	
Voltage	24V AC/DC ± 20%
Power consumption	2W @ 24VDC; 3VA @ 24VAC
Universal Inputs	
No. of Inputs	8
Temperature Input	Measurement with attached RTDs accuracy ±0,1°C For sensor Pt1000 and Ni1000 use only 16bit resolution
Voltage Input	Voltage measurement from 0 to 10V Input impedance 100kΩ Measurement accuracy ±0,1% Measurement resolution 3mV@12bit and 1mV@16bit

Figure 32. 8U-IP device page

4.3 Local I/O status and configuration

4.3.1 Universal Inputs

This page allows for entering the configuration parameters and showing the actual value of the Universal Inputs. To open this page, please navigate to Local IO tab and choose Universal Inputs from the submenu.

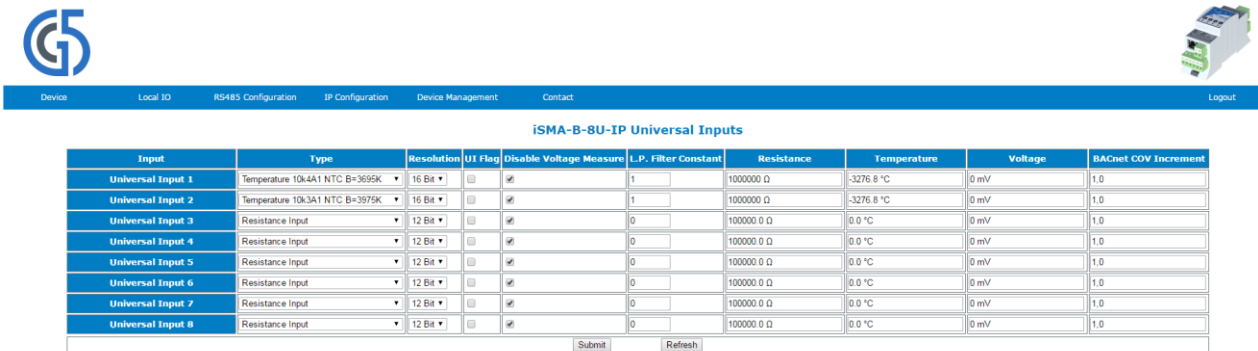

Figure 30. 8U-IP Universal Inputs page

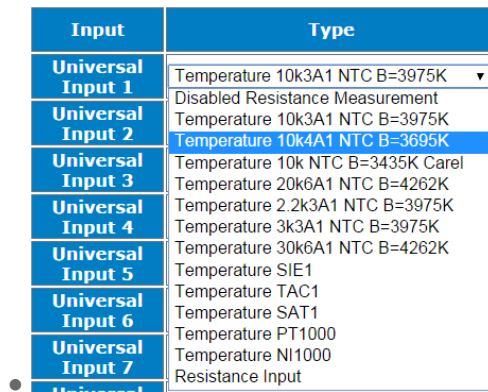

Figure 34. Types of sensors

Universal Input table contains the following fields:

- **Sensor type** (Read & Write) allows for setting a different type of sensor.
- **Resolution** (Read & Write), resolution measurement 12bits / 16bits (for PT1000 and Ni1000 sensors please use 16bits).
- **UI Flag** (Read Only), status of UI as DI.
- **Disable Voltage Measurement** (Read & Write), disables voltage measuring for resistance measurement only.
- **L.P. Filter Constant** (Read & Write), parameter of time, constant low pass filter in seconds. Valid values must be between 0 and 60 seconds (default 2s). Setting value 0 will disable the filter.
- **Resistance** (Read Only), in ohms from 0 to 1000k [Ω].

- **Temperature** (Read Only), in Celsius with an accuracy of 1 decimal [°C].
- **Voltage** (Read Only) in millivolts [mV].

WARNING! To save the changes please use the “Submit” button.

4.3.2 Configuration of special application mode

This page allows for entering the configuration parameters and showing the actual value of Special application modes. To open this page, please navigate to Local IO tab and

Input	Type	Resolution	UT Flag	Disable Voltage Measure	L.P. Filter Constant	Resistance	Temperature	Voltage	BACnet COV Increment
Universal Input 1	Temperature 10k3A1 NTC B=3975K	12 Bit	<input type="checkbox"/>	<input type="checkbox"/>	0	1000000 Ω	-3276.8 °C	0 mV	1.0
Universal Input 2		12 Bit	<input type="checkbox"/>	<input checked="" type="checkbox"/>	0	0 Ω	0.0 °C	0 mV	1.0
Universal Input 3	Temperature 10k3A1 NTC B=3975K	12 Bit	<input type="checkbox"/>	<input type="checkbox"/>	60	1000000 Ω	-3276.8 °C	0 mV	1.0
Universal Input 4	Disabled Resistance Measurement	12 Bit	<input type="checkbox"/>	<input type="checkbox"/>	3	0 Ω	0.0 °C	0 mV	1.0

Input	Block Input	Input Mode	Command	Mode Time	Setpoint	Diff
Universal Input 1	<input type="checkbox"/>	Heating	<input type="checkbox"/>	1000	21.0 °C	0.0 °C
Universal Input 2	<input type="checkbox"/>	Bistable Relay	<input type="checkbox"/>	10	23.0 °C	0.3 °C
Universal Input 3	<input type="checkbox"/>	Bistable Relay	<input type="checkbox"/>	3	25.0 °C	3.0 °C
Universal Input 4	<input type="checkbox"/>	Heating	<input type="checkbox"/>	0	0.0 °C	0.0 °C

choose Universal Inputs from the submenu.

Figure 35. 4U40-IP Universal Inputs page

Input	Block Input	Input Mode
Universal Input 1	<input type="checkbox"/>	<ul style="list-style-type: none"> Ordinary IO Ordinary IO Monostable Relay Bistable Relay Time Relay NO [ms] Time Relay NC [ms] Time Relay NO [s] Time Relay NC [s] Input Forwarding Heating Cooling
Universal Input 2	<input type="checkbox"/>	
Universal Input 3	<input type="checkbox"/>	
Universal Input 4	<input type="checkbox"/>	

Figure 36. Special application modes

Special Modes Configuration table includes the following fields:

- **Block Input** (Read & Write) allows for blocking a particular input (except for heating/cooling modes).
- **Input Mode** (Read & Write), allows for selecting the Special Application Mode for a particular input (Ordinary IO in default).
- **Command** (Read & Write), execution of the Special Application Modes (except for input forwarding, heating/cooling modes).
- **Mode Time** (Read & Write), time base for time relay application modes (the unit depends on the selected mode: [ms] or [s]).

- **Setpoint** (Read & Write, 4U40-H-IP only), setpoint value for heating/cooling modes.
In default 0.
- **Differential** (Read & Write, 4U40-H-IP only), differential value for heating/cooling modes.
In default 0.

WARNING! To save the changes please use the “Submit” button.

4.3.3 Digital Inputs

This page allows for entering the configuration parameters and showing the actual value of Digital Inputs. To open this page, please navigate to Local IO tab and choose the Digital



Input	State	Reset Flag	Counter State	Counter State To Set
Digital Input 1	<input type="checkbox"/>	<input type="checkbox"/>	13	13
Digital Input 2	<input type="checkbox"/>	<input type="checkbox"/>	2	
Digital Input 3	<input type="checkbox"/>	<input type="checkbox"/>	2	2
Digital Input 4	<input type="checkbox"/>	<input type="checkbox"/>	2	2
Digital Input 5	<input type="checkbox"/>	<input type="checkbox"/>	2	
Digital Input 6	<input type="checkbox"/>	<input type="checkbox"/>	2	2
Digital Input 7	<input type="checkbox"/>	<input type="checkbox"/>	2	2
Digital Input 8	<input type="checkbox"/>	<input type="checkbox"/>	2	
Digital Input 9	<input type="checkbox"/>	<input type="checkbox"/>	2	2
Digital Input 10	<input type="checkbox"/>	<input type="checkbox"/>	2	2
Digital Input 11	<input type="checkbox"/>	<input type="checkbox"/>	2	
Digital Input 12	<input type="checkbox"/>	<input type="checkbox"/>	2	2

Inputs from the submenu.

Figure 37. MIX38-IP Digital Inputs page

Digital Input table includes the following fields:

- **State** (Read Only), actual input state.
- **Reset Flag** (Read & Write), reset of pulses value (leaving reset active will reset the value of the pulses).
- **Counter State** (Read Only), actual value of pulses saved in EEPROM.
- **Counter State To Set** (Read & Write), allows for setting the value of the counter.

WARNING! To save the changes please use the “Submit” button.

4.3.4 Digital Outputs

This page allows for entering the configuration parameters and showing the actual value of the Digital Outputs. To open this page, please navigate to Local IO tab and choose

Digital Outputs from the submenu.



Output	State	Default State
Digital Output 1	<input type="checkbox"/>	<input type="checkbox"/>
Digital Output 2	<input type="checkbox"/>	<input type="checkbox"/>
Digital Output 3	<input type="checkbox"/>	<input type="checkbox"/>
Digital Output 4	<input type="checkbox"/>	<input type="checkbox"/>
Digital Output 5	<input type="checkbox"/>	<input type="checkbox"/>
Digital Output 6	<input type="checkbox"/>	<input type="checkbox"/>
Digital Output 7	<input type="checkbox"/>	<input type="checkbox"/>
Digital Output 8	<input type="checkbox"/>	<input type="checkbox"/>
Digital Output 9	<input type="checkbox"/>	<input type="checkbox"/>
Digital Output 10	<input type="checkbox"/>	<input type="checkbox"/>
Digital Output 11	<input type="checkbox"/>	<input type="checkbox"/>
Digital Output 12	<input type="checkbox"/>	<input type="checkbox"/>
Watchdog (s)	<input type="text" value="0"/>	

Figure 38. MIX38-IP Digital Outputs page

The Digital Outputs table includes the following fields:

- **State** (Read & Write), actual state of digital output.
- **Default State** (Read & Write), output state after power-up and watchdog operation.
- **Watchdog** (Read & Write), watchdog value of the device in seconds.

WARNING! To save the changes, please use the “Submit” button.

4.3.5 Analog Outputs

This page allows for entering the configuration parameters and showing the actual value of the Analog Outputs. To open this page, please navigate to Local IO tab and choose the Analog Outputs from the submenu.



Output	Value	Type	Default Value	Digital Output	Default Digital Output	Hand State Output	BACnet COV Increment
Analog Output 1	<input type="text" value="0"/> mV	Voltage 0-10V ▾	<input type="text" value="0"/> mV	<input type="checkbox"/>	<input type="checkbox"/>	Auto	<input type="text" value="1.0"/>
Analog Output 2	<input type="text" value="0"/> mV	Voltage 0-10V ▾	<input type="text" value="0"/> mV	<input type="checkbox"/>	<input type="checkbox"/>	Auto	<input type="text" value="1.0"/>
Analog Output 3	<input type="text" value="0"/> mV	Voltage 0-10V ▾	<input type="text" value="0"/> mV	<input type="checkbox"/>	<input type="checkbox"/>	Auto	<input type="text" value="1.0"/>
Analog Output 4	<input type="text" value="0"/> %	PWM 1 Hz ▾	<input type="text" value="0"/> %	<input type="checkbox"/>	<input type="checkbox"/>	Auto	<input type="text" value="1.0"/>
Watchdog (s)	<input type="text" value="0"/>						

Figure 39. 4U4A-H-IP Analog Outputs value

The Analog Outputs table includes the following fields:

- **Value** (Read & Write), actual value of analog output in millivolts [mV].
- **Type** (Read & Write), analog output working mode voltage / PWM.
- **Default Value** (Read & Write), default output value after power-up and watchdog operation.
- **Digital Output** (Read & Write), output status flag for DO mode.

- **Default Digital Output** (Read & Write), default output status for DO mode.
- **Watchdog** (Read & Write), device watchdog value in seconds.
- **Hand State Output** (Read Only, MINI series only), manually overrides the status of the potentiometer

WARNING! To save the changes please use the “Submit” button.

4.4 RS485 Configuration

This page allows for entering the configuration parameters and showing the information

Modbus Settings	
Actual Baud Rate	115200
User Baud Rate	76800
Stop Bits	1 BIT
Data Bits	8 BITS
Parity Bits	None
RS485 Biasing Resistors	<input type="checkbox"/>
Statistics	
Received Frames	0
Error Frames	0
Transmitted Frames	0

of RS485 port of the controllers.

Figure 40. RS485 configuration page

This page allows for setting parameters such as:

- **Baud rate** (Read Only), RS485 baud rate from 2400 up to 115200.
- **Modbus Config** (Read Only), Modbus Protocol Type- RTU or ASCII.
- **Stop Bits** (Read & Write), number of the stop bits (1 or 2).
- **Data Bits** (Read & Write), number of data bits transmitted in a single byte (7 or 8).
- **Parity Bits** (Read & Write), transmission protection as a parity bit added before stop bit (bits).
- **RS485 Biasing Resistors** , activation of the biasing resistors only for MINI modules with a hardware version ≥ 2.0 (option unavailable in MIX modules)
- **Received Frames** (Read Only), number of received frames.
- **Transmitted Frames** (Read Only), number of transmitted frames.

- Error Frames (Read Only), number of error frames.

WARNING! To save the changes please use the “Submit” button.

4.5 IP Configuration

This page allows for changing the parameters of Ethernet port, Modbus TCP and BACnet IP.

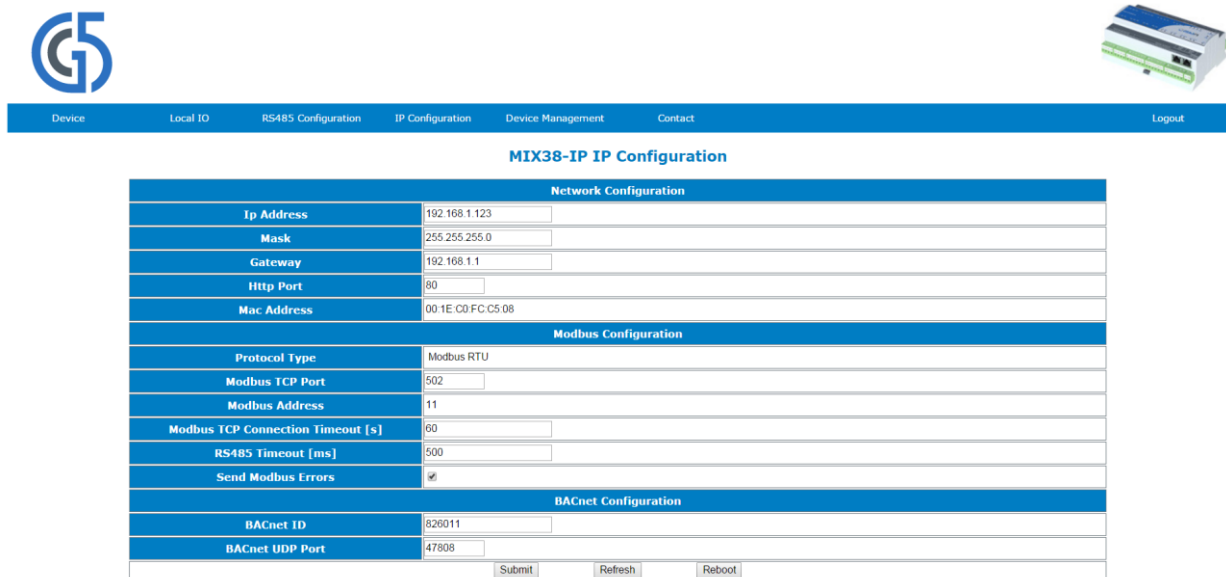

Network Configuration	
Ip Address	192.168.1.123
Mask	255.255.255.0
Gateway	192.168.1.1
Http Port	80
Mac Address	00:1E:C0:FC:C5:08
Modbus Configuration	
Protocol Type	Modbus RTU
Modbus TCP Port	502
Modbus Address	11
Modbus TCP Connection Timeout [s]	60
RS485 Timeout [ms]	500
Send Modbus Errors	<input checked="" type="checkbox"/>
BACnet Configuration	
BACnet ID	826011
BACnet UDP Port	47808

Figure 41. IP configuration page

This page allows for setting the parameters such as:

- IP Address (Read & Write), IP address of the controller Ethernet interface.
- Mask (Read & Write), network mask.
- Gateway (Read & Write), network default gateway.
- Http Port (Read & Write), http port.
- Mac Address (Read Only), Ethernet interface MAC address.
- Protocol Type (Read Only), Dip Switch protocol selection.
- Modbus TCP Port (Read & Write), Modbus TCP port number, default 502.
- Modbus Address (Read Only). Modbus device address set by rotary switches.
- Modbus TCP Communication Timeout (Read & Write), timeout for TCP/IP messages.
- RS485 Timeout (Read & Write), timeout for Modbus RTU/ASCII messages.
- Send Modbus Errors (Read Only), Enable / Disable sending Modbus error messages.
- BACnet ID (Read & Write), BACnet ID set by rotary switches; this value can be overridden by the user, once overridden by the user changing rotary switches it will not affect BACnet ID.

- BACnet UDP port (Read & Write), BACnet IP port.

WARNING! To save the changes, please first click the “Submit” button and then the “Reboot” button

4.6 Device management



This page allows for changing the password and rebooting device the device remotely.

Figure 42. Device management page

Procedure of changing the password of the device:

- enter the current device password in the field - Current Device Password,
- enter the new device password in the field - New Device Password,
- enter the new device password in the field once again - Confirm New Device Password,
- to confirm the password change, please click “Submit” button,
- please logout, and login again using the new password.

WARNING! To reset the password to default, refer to “Restoring default settings”

4.7 Contact

This page displays information about Manufacture web address and email to the technical support.

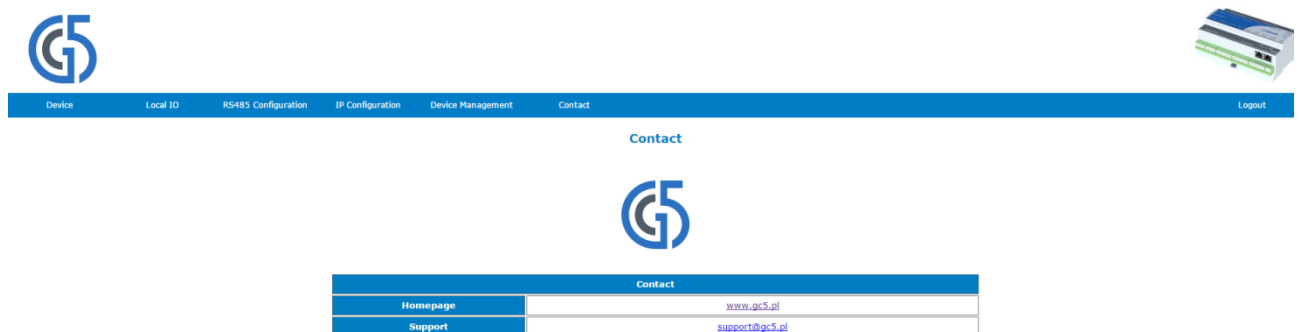

Figure 43. Contact page view

5 Modbus TCP/IP modules

5.1 Modbus TCP/IP

The device simultaneously supports up to **4 Modbus TCP clients**. If a fifth device wants to connect to the module, TCP connection will be rejected. In order to secure the module before filling up the call list, a mechanism was introduced a mechanism for monitoring each of the Modbus TCP connections. There is a parameter called **Modbus TCP Communication Timeout** (default 60s). If during this time no requests come from the Modbus TCP client, the module closes the connection.

To read the internal registers of the module, correct MODBUS TCP frame needs to be generated with address according to the setting of dipswitch. If the address is different, the frame will be sent to the RS485 port.

If the module receives an incorrect MODBUS TCP frame, it sends back a frame with error code:

0x01 - if the function code in the query is not supported

0x02 - if the address of the register is invalid

0x03 - if in the there is an improper amount of data in the query

If the query is correct, the device instantly generates an answer with the data or an acknowledgment of the receipt of data, depending on the query.

5.2 Module as Modbus TCP/IP Gateway to RS485

All IP version modules are equipped with a built-in Modbus TCP/IP for RS485 gateway which allows for establishing a connection with RS485, additional I/O modules, or 3rd party Modbus devices. In order to ensure proper operation of Modbus Gateway please make sure that all parameters of RS485 (Baud Rate, Stop Bits etc.) of all the devices connected to RS485 (Gateway and additional I/O modules/devices) are same.

Operation of the gateway is based on checking the MODBUS address in the MODBUS TCP query. If the address is different from the set on the dipswitch, the data frame from the query is converted to MODBUS RTU/ASCII, and sent to the RS485 port. Then the module waits for an answer from the device connected to the RS485; if the slave does not respond within the estimated time defined by the **RS485 Timeout** (default 500ms), an exception response will be given: error code 0x0B. If the slave answered the correct frame, it is converted to Modbus TCP, and sent to the master.

In case of not receiving a valid frame, the module in the gateway functionality sends error code 0x0B. When receiving this error code some system do not repeat the query in accordance with the settings. No retry may result in immediate going point to down mode. That is why the modules have the ability to block sending the information about errors (**Send Modbus Errors** setting from built-in web or iSMA Configurator). Then, in the

absence of any response, the system retries the request according to the settings.

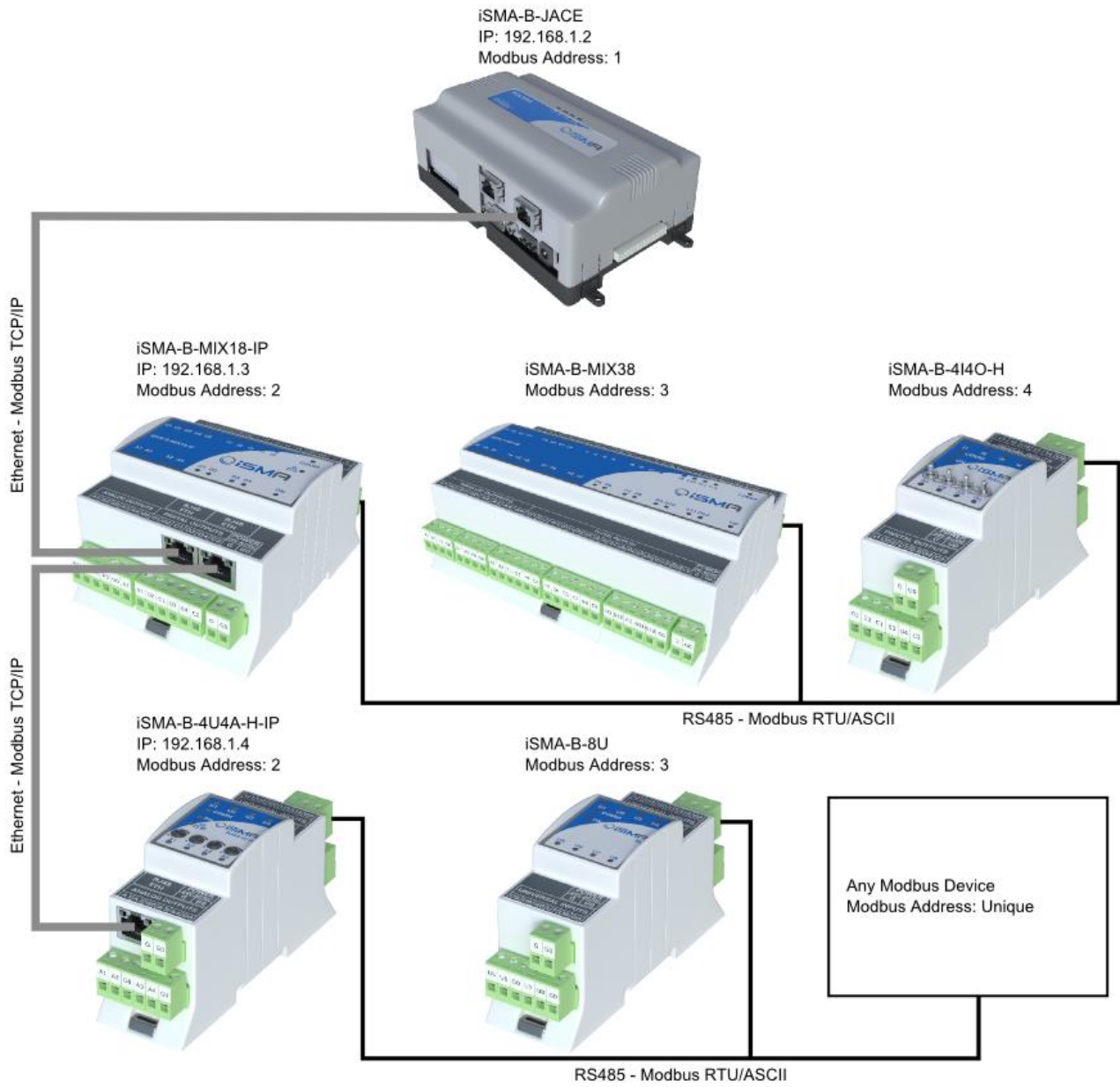

Figure 44. Gateway Modbus TCP/IP to RS485; an example

6 List of all Modbus Registers

Below is a table with all the registers available for all types of modules. Please notice that for some types of modules some of the registers are not available according to the physical number and types of Inputs and Outputs.

Modbus Addr	Dec Addr	Hex Addr	Register name	Access	Description
30001	0	0x00	VERSION AND MODULE TYPE	Read Only	
30002	1	0x01	MODULE ADDRESS (state of switch)	Read Only	
30003	2	0x02	BAUD RATE AND PROTOCOL (state of switch)	Read Only	
30004	3	0x03	COUNTER OF RECEIVED FRAMES (32 – bits)	Read Only	Default state is 0 Reset at the unit start and change of transmission parameters.
30006	5	0x05	COUNTER OF FRAMES WITH ERROR (32 – bits)	Read Only	Default state is 0 Reset at the unit start and change of transmission parameters.
30008	7	0x07	COUNTER OF SENT FRAMES (32 – bits)	Read Only	Default state is 0 Reset at the unit start and change of transmission parameters.
30015	14	0xE	STATUS OF MANUAL OPERATION	Read Only	Status of manual operation DO, TO, and AO for MINI series modules
30016	15	0x0F	STATE OF DIGITAL INPUTS	Read Only	
30017	16	0x10	STATE OF UNIVERSAL INPUTS WORKING AS DIGITAL INPUTS	Read Only	Status of Universal Inputs operating as digital inputs
40001	0	0x00	DEVICE ACTIONS	Read & Write	Allows for enabling 1 of 3 device actions
40018	17	0x11	STATE OF DIGITAL OUTPUTS	Read & Write	State of Digital Outputs
40019	18	0x12	STATE OF ANALOG OUTPUTS WORKING AS DIGITAL OUTPUTS	Read & Write	State of Analog Outputs operating as Digital Outputs
40020	19	0x13	DIGITAL INPUTS COMMAND REGISTER	Read & Write	Digital Inputs command register
40021	20	0x14	DIGITAL INPUTS BLOCKING	Read & Write	Digital Inputs blocking register

Modbus Addr	Dec Addr	Hex Addr	Register name	Access	Description
40022	21	0x15	COUNTER RESET	Read & Write	Sets bit in register to reset the corresponding counter.
40023	22	0x16	COUNTER 1 LSB	Read & Write Memory	32-bit counters for each of the Digital Input counting pulses.
40024	23	0x17	COUNTER 1 MSB		
40025	24	0x18	COUNTER 2 LSB	Read & Write Memory	
40026	25	0x19	COUNTER 2 MSB		
40027	26	0x1A	COUNTER 3 LSB	Read & Write Memory	
40028	27	0x1B	COUNTER 3 MSB		
40029	28	0x1C	COUNTER 4 LSB	Read & Write Memory	
40030	29	0x1D	COUNTER 4 MSB		
40031	30	0x1E	COUNTER 5 LSB	Read & Write Memory	
40032	31	0x1F	COUNTER 5 MSB		
40033	32	0x20	COUNTER 6 LSB	Read & Write Memory	
40034	33	0x21	COUNTER 6 MSB		
40035	34	0x22	COUNTER 7 LSB	Read & Write Memory	
40036	35	0x23	COUNTER 7 MSB		
40037	36	0x24	COUNTER 8 LSB	Read & Write Memory	
40038	37	0x25	COUNTER 8 MSB		
40039	38	0x26	COUNTER 9 LSB	Read & Write Memory	
40040	39	0x27	COUNTER 9 MSB		
40041	40	0x28	COUNTER 10 LSB	Read & Write Memory	
40042	41	0x29	COUNTER 10 MSB		
40043	42	0x2A	COUNTER 11 LSB	Read & Write Memory	
40044	43	0x2B	COUNTER 11 MSB		
40045	44	0x2C	COUNTER 12 LSB	Read & Write Memory	
40046	45	0x2D	COUNTER 12 MSB		
30071	70	0x46	UIVERSAL INPUT VOLTAGE 1	Read Only	Voltage measurement value is expressed in mV.
30072	71	0x47	UIVERSAL INPUT	Read Only	

Modbus Addr	Dec Addr	Hex Addr	Register name	Access	Description
			TEMPERATURE 1		
30073	72	0x48	UIVERSAL INPUT VOLTAGE 2	Read Only	Formula for the current measurements: $I = \frac{U}{500}$ where: U – register value, 500 – value of attached resistor
30074	73	0x49	UIVERSAL INPUT TEMPERATURE 2	Read Only	
30075	74	0x4A	UIVERSAL INPUT VOLTAGE 3	Read Only	Temperature is expressed in Celsius degrees * 10 For a result, divide the registry value by 10:
30076	75	0x4B	UIVERSAL INPUT TEMPERATURE 3	Read Only	
30077	76	0x4C	UIVERSAL INPUT VOLTAGE 4	Read Only	$T = \frac{\text{registervalue}}{10}$
30078	77	0x4D	UIVERSAL INPUT TEMPERATURE 4	Read Only	
30079	78	0x4E	UIVERSAL INPUT VOLTAGE 5	Read Only	Selection of the type sensor is completed UNIVERSAL INPUT CONFIGURATION register from 40151 to 40158 for each input separately
30080	79	0x4F	UIVERSAL INPUT TEMPERATURE 5	Read Only	
30081	80	0x50	UIVERSAL INPUT VOLTAGE 6	Read Only	
30082	81	0x51	UIVERSAL INPUT TEMPERATURE 6	Read Only	
30083	82	0x52	UIVERSAL INPUT VOLTAGE 7	Read Only	
30084	83	0x53	UIVERSAL INPUT TEMPERATURE 7	Read Only	
30085	84	0x54	UIVERSAL INPUT VOLTAGE 8	Read Only	
30086	85	0x55	UIVERSAL INPUT TEMPERATURE 8	Read Only	
30087	86	0x56	UIVERSAL INPUT VOLTAGE 1	Read Only	
30088	87	0x57	UIVERSAL INPUT VOLTAGE 2	Read Only	
30089	88	0x58	UIVERSAL INPUT VOLTAGE 3	Read Only	
30090	89	0x59	UIVERSAL INPUT VOLTAGE 4	Read Only	
30091	90	0x5A	UIVERSAL INPUT VOLTAGE 5	Read Only	
30092	91	0x5B	UIVERSAL INPUT VOLTAGE 6	Read Only	

Modbus Addr	Dec Addr	Hex Addr	Register name	Access	Description
30093	92	0x5C	UIVERSAL INPUT VOLTAGE 7	Read Only	
30094	93	0x5D	UIVERSAL INPUT VOLTAGE 8	Read Only	
30095	94	0x5E	UIVERSAL INPUT TEMPERATURE 1	Read Only	
30096	95	0x5F	UIVERSAL INPUT TEMPERATURE 2	Read Only	
30097	96	0x60	UIVERSAL INPUT TEMPERATURE 3	Read Only	
30098	97	0x61	UIVERSAL INPUT TEMPERATURE 4	Read Only	
30099	98	0x62	UIVERSAL INPUT TEMPERATURE 5	Read Only	
30100	99	0x63	UIVERSAL INPUT TEMPERATURE 6	Read Only	
30101	100	0x64	UIVERSAL INPUT TEMPERATURE 7	Read Only	
30102	101	0x65	UIVERSAL INPUT TEMPERATURE 8	Read Only	
30103	102	0x66	RESISTIVE INPUT 1 LSB	Read Only	Resistance measurement result expressed in Ω
30104	103	0x67	RESISTIVE INPUT 1 MSB	Read Only	
30105	104	0x68	RESISTIVE INPUT 2 LSB	Read Only	
30106	105	0x69	RESISTIVE INPUT 2 MSB	Read Only	
30107	106	0x6A	RESISTIVE INPUT 3 LSB	Read Only	
30108	107	0x6B	RESISTIVE INPUT 3 MSB	Read Only	
30109	108	0x6C	RESISTIVE INPUT 4 LSB	Read Only	
30110	109	0x6D	RESISTIVE INPUT 4 MSB	Read Only	
30111	110	0x6E	RESISTIVE INPUT 5 LSB	Read Only	
30112	111	0x6F	RESISTIVE INPUT 5 MSB	Read Only	
30113	112	0x70	RESISTIVE INPUT 6 LSB	Read Only	
30114	113	0x71	RESISTIVE INPUT 6 MSB	Read Only	
30115	114	0x72	RESISTIVE INPUT 7 LSB	Read Only	
30116	115	0x73	RESISTIVE INPUT 7 MSB	Read Only	
30117	116	0x74	RESISTIVE INPUT 8 LSB	Read Only	
30118	117	0x75	RESISTIVE INPUT 8 MSB	Read Only	
40121	120	0x78	VALUE OF ANALOG OUTPUT 1	Read & Write	

Modbus Addr	Dec Addr	Hex Addr	Register name	Access	Description												
40122	121	0x79	VALUE OF ANALOG OUTPUT 2	Read & Write	The voltage at the Analog Outputs expressed in mV within the range from 0 to 10000mV												
40123	122	0x7A	VALUE OF ANALOG OUTPUT 3	Read & Write													
40124	123	0x7B	VALUE OF ANALOG OUTPUT 4	Read & Write													
40125	124	0x7C	VALUE OF ANALOG OUTPUT 5	Read & Write													
40126	125	0x7D	VALUE OF ANALOG OUTPUT 6	Read & Write													
30125	124	0x7C	HAND STATUS VALUE 1	Read Only		The current value of Analog Output in the hand mode for MINI with AO											
30126	125	0x7D	HAND STATUS VALUE 2	Read Only													
30127	126	0x7E	HAND STATUS VALUE 3	Read Only													
30128	127	0x7F	HAND STATUS VALUE 4	Read Only													
30130	129	0x81	HARDWARE_VERSION	Read Only	The current hardware version of a device												
30131	130	0x82	MAC_ADDRESS (32 – bits)	Read Only	The MAC address of a device												
40136	135	0x87	BAUD RATE	Read & Write Memory	Transmission speed is defined by the user calculated using the formula: <i>Baudrate = (registervalue) · 10</i> The value is considered only when sections 1, 2, and 3 of S3 switch are in the OFF position The default value is 7680 (76800 bps)												
40137	136	0x88	STOP BITS	Read & Write Memory	Supported values are 1 and 2 The default value is 1												
40138	137	0x89	DATA BITS	Read & Write Memory	Supported values are 7 and 8 The default value is 8												
40139	138	0x8A	PARITY BIT	Read & Write Memory	Parity bit (40139) The default value is 0 (no parity) Allowed values: <table border="1" data-bbox="1093 1664 1485 1966"> <thead> <tr> <th>Value</th> <th>Description</th> </tr> </thead> <tbody> <tr> <td>0 (default)</td> <td>None</td> </tr> <tr> <td>1</td> <td>Odd</td> </tr> <tr> <td>2</td> <td>Even</td> </tr> <tr> <td>3</td> <td>Always 1</td> </tr> <tr> <td>4</td> <td>Always 0</td> </tr> </tbody> </table>	Value	Description	0 (default)	None	1	Odd	2	Even	3	Always 1	4	Always 0
Value	Description																
0 (default)	None																
1	Odd																
2	Even																
3	Always 1																
4	Always 0																
40140	139	0x8B	RESPONSE DELAY	Read &	Delay in ms before sending the												

Modbus Addr	Dec Addr	Hex Addr	Register name	Access	Description
				Write Memory	response The default value is 0.
40141	140	0x8C	WATCHDOG TIME	Read & Write Memory	Time in second before watchdog reset in case no transmission. A value of 0 disables Watchdog. The default value is 0s
40143	142	0x8E	DEFAULT STATE OF DIGITAL OUTPUTS	Read & Write Memory	State of Digital Outputs assigned at the start of the module and watchdog reset. The default value is 0.
40144	143	0x8F	DEFAULT STATE OF ANALOG OUTPUTS (DIGITAL)	Read & Write Memory	State of Analog Outputs assigned at the start of the module and watchdog reset. The default value is 0.
40145	144	0x90	DEFAULT STATE OF ANALOG OUTPUT 1	Read & Write Memory	In the registers is stored value that appears at the Analog Output after power on or watchdog reset. The default value is 0.
40146	145	0x91	DEFAULT STATE OF ANALOG OUTPUT 2	Read & Write Memory	
40147	146	0x92	DEFAULT STATE OF ANALOG OUTPUT 3	Read & Write Memory	
40148	147	0x93	DEFAULT STATE OF ANALOG OUTPUT 4	Read & Write Memory	
40149	148	0x94	DEFAULT STATE OF ANALOG OUTPUT 5	Read & Write Memory	
40150	149	0x95	DEFAULT STATE OF ANALOG OUTPUT 6	Read & Write Memory	
40151	150	0x96	UNIVERSAL INPUT CONFIGURATION 1	Read & Write Memory	
40152	151	0x97	UNIVERSAL INPUT CONFIGURATION 2	Read & Write Memory	
40153	152	0x98	UNIVERSAL INPUT CONFIGURATION 3	Read & Write Memory	
40154	153	0x99	UNIVERSAL INPUT CONFIGURATION 4	Read & Write Memory	

Value	Description / Sensor
0	Resistance measurement off
1	10K3A1 NTC
2	10K4A1 NTC

Modbus Addr	Dec Addr	Hex Addr	Register name	Access	Description	
40155	154	0x9A	UNIVERSAL INPUT CONFIGURATION 5	Read & Write Memory	3	10K NTC Carel
					4	20K6A1 NTC
40156	155	0x9B	UNIVERSAL INPUT CONFIGURATION 6	Read & Write Memory	5	2,2K3A1 NTC B=3975K
					6	3K3A1 NTC
					7	30K6A1 NTC
40157	156	0x9C	UNIVERSAL INPUT CONFIGURATION 7	Read & Write Memory	8	SIE1
					9	TAC1
40158	157	0x9D	UNIVERSAL INPUT CONFIGURATION 8	Read & Write Memory	10	SAT1
					16	Pt1000
					17	Ni1000
					+128	Voltage measurement off
40159	158	0x9E	FILTER TIME CONSTANT OF THE UNIVERSAL INPUT 1	Read & Write Memory	Filter time constant, expressed in seconds in the range from 0 to 60 seconds. A value of 0 disables the filter. The default value is 2s.	
40160	159	0x9F	FILTER TIME CONSTANT OF THE UNIVERSAL INPUT 2	Read & Write Memory		
40161	160	0xA0	FILTER TIME CONSTANT OF THE UNIVERSAL INPUT 3	Read & Write Memory		
40162	161	0xA1	FILTER TIME CONSTANT OF THE UNIVERSAL INPUT 4	Read & Write Memory		
40163	162	0xA2	FILTER TIME CONSTANT OF THE UNIVERSAL INPUT 5	Read & Write Memory		
40164	163	0xA3	FILTER TIME CONSTANT OF THE UNIVERSAL INPUT 6	Read & Write Memory		
40165	164	0xA4	FILTER TIME CONSTANT OF THE UNIVERSAL INPUT 7	Read & Write Memory		
40166	165	0xA5	FILTER TIME CONSTANT OF THE UNIVERSAL INPUT 8	Read & Write Memory		
40167	166	0xA6	RESOLUTION OF THE UNIVERSAL INPUTS	Read & Write Memory	Resolution of the Analog Inputs. When a bit is set, the measurement at corresponding input is performed with	

Modbus Addr	Dec Addr	Hex Addr	Register name	Access	Description														
					16-bit resolution. By default, all the measurements are performed with 12-bit resolution.														
40168	167	0xA7	ANALOG OUTPUT CONFIGURATION 1	Read & Write Memory	Configures the mode of the Analog Output according to the following table:														
40169	168	0xA8	ANALOG OUTPUT CONFIGURATION 2	Read & Write Memory															
40170	169	0xA9	ANALOG OUTPUT CONFIGURATION 3	Read & Write Memory															
40171	170	0xAA	ANALOG OUTPUT CONFIGURATION 4	Read & Write Memory															
40172	171	0xAB	ANALOG OUTPUT CONFIGURATION 5	Read & Write Memory															
40173	172	0xAC	ANALOG OUTPUT CONFIGURATION 6	Read & Write Memory															
						<table border="1"> <thead> <tr> <th>Value</th> <th>Description</th> </tr> </thead> <tbody> <tr> <td>0 (default)</td> <td>Voltage output 0-10V</td> </tr> <tr> <td>1</td> <td>PWM 1Hz</td> </tr> <tr> <td>2</td> <td>PWM 10Hz</td> </tr> <tr> <td>3</td> <td>PWM 100Hz</td> </tr> <tr> <td>4</td> <td>PWM 0.1Hz</td> </tr> <tr> <td>5</td> <td>PWM 0.01Hz</td> </tr> </tbody> </table>	Value	Description	0 (default)	Voltage output 0-10V	1	PWM 1Hz	2	PWM 10Hz	3	PWM 100Hz	4	PWM 0.1Hz	5
Value	Description																		
0 (default)	Voltage output 0-10V																		
1	PWM 1Hz																		
2	PWM 10Hz																		
3	PWM 100Hz																		
4	PWM 0.1Hz																		
5	PWM 0.01Hz																		
40176	175	0xAF	DIGITAL INPUT 1 CONFIGURATION MODE	Read & Write Memory	DIGITAL INPUT CONFIGURATION MODE table:														
40177	176	0xB0	DIGITAL INPUT 1 TIME VALUE	Read & Write Memory															
40178	177	0xB1	DIGITAL INPUT 1 SETPOINT	Read & Write Memory															
40179	178	0xB2	DIGITAL INPUT 1 DIFFERENTIAL	Read & Write Memory															
40180	179	0xB3	DIGITAL INPUT 2 CONFIGURATION MODE	Read & Write Memory															
40181	180	0xB4	DIGITAL INPUT 2 TIME VALUE	Read & Write Memory															
40182	181	0xB5	DIGITAL INPUT 2 SETPOINT	Read & Write Memory															
40183	182	0xB6	DIGITAL INPUT 2	Read &	DIGITAL INPUT TIME VALUE in [ms] or in [s] – depending on mode selection														

Modbus Addr	Dec Addr	Hex Addr	Register name	Access	Description
			DIFFERENTIAL	Write Memory	SETPOINT in °C multiplied by 10 Default value = 0
40184	183	0xB7	DIGITAL INPUT 3 CONFIGURATION MODE	Read & Write Memory	DIFFERENTIAL in °C multiplied by 10 Default value = 0
40185	184	0xB8	DIGITAL INPUT 3 TIME VALUE	Read & Write Memory	
40186	185	0xB9	DIGITAL INPUT 3 SETPOINT	Read & Write Memory	
40187	186	0xBA	DIGITAL INPUT 3 DIFFERENTIAL	Read & Write Memory	
40188	187	0xBB	DIGITAL INPUT 4 CONFIGURATION MODE	Read & Write Memory	
40189	188	0xBC	DIGITAL INPUT 4 TIME VALUE	Read & Write Memory	
40190	189	0xBD	DIGITAL INPUT 4 SETPOINT	Read & Write Memory	
40191	190	0xBE	DIGITAL INPUT 4 DIFFERENTIAL	Read & Write Memory	

7 List of supported temperature sensors

No	1	No	2
Sensor	<i>10K3A1</i>	Sensor	<i>10K4A1</i>
β coefficient	<i>3975K</i>	β coefficient	<i>3695K</i>
Manufacturers	<i>Aquatrol, Cylon, Honeywell, Johnson, Satchwell, Seachange</i>	Manufacturers	<i>Andover, Delta Controls, Siebe, York</i>
$^{\circ}\text{C}$	Ω	$^{\circ}\text{C}$	Ω
-50	667828	-50	441667
-45	491749	-45	330749
-40	335671	-40	239831
-35	241840	-35	181532
-30	176683	-30	135233
-25	131251	-25	105081
-20	96974	-20	78930
-15	72895	-15	61030
-10	55298	-10	47549
-5	42314	-5	37316
0	32650	0	29490
5	25396	5	23462
10	19904	10	18787
15	15714	15	15136
20	12494	20	12268
25	10000	25	10000
30	8056	30	8197
35	6530	35	6754
40	5325	40	5594
45	4367	45	4656
50	3601	50	3893
55	2985	55	3271
60	2487	60	2760
65	2082	65	2339
70	1751	70	1990
75	1480	75	1700
80	1256	80	1458
85	1070	85	1255

No	1	No	2
90	916	90	1084
95	787	95	939
100	678	100	817
105	587	105	713
110	510	110	624
115	444	115	547
120	388	120	482
125	340	125	426

No Sensor β coefficient °C	3	No Sensor β coefficient Manufacturers °C	4
	<i>10K Carel</i>		<i>20K6A1</i>
	<i>3435K</i>		<i>4262K</i>
	Ω		Ω
-45	247700	-40	806800
-40	188500	-35	574400
-35	144100	-30	413400
-30	111300	-25	300400
-25	86430	-20	220600
-20	67770	-15	163480
-15	53410	-10	122260
-10	42470	-5	92220
-5	33900	0	70140
0	27280	5	53780
5	22050	10	41540
10	17960	15	32340
15	14690	20	25340
20	12090	25	20000
25	10000	30	15886
30	8313	35	12698
35	6940	40	10212
40	5827	45	8260
45	4912	50	6718
50	4161	55	5494
55	3536	60	4518
60	3020	65	3732
65	2588	70	3098
70	2228	75	2586
75	1924	80	2166
80	1668	85	1823
85	1451	90	1541
90	1266	95	1308
95	1108	100	1114
100	973	105	953

No	3	No	4
105	857	110	818
110	758	115	704
115	672	120	609
120	597	125	528
125	531		

No Sensor β coefficient Manufacturers $^{\circ}\text{C}$	5	No Sensor β coefficient Manufacturers $^{\circ}\text{C}$	6
	<i>2.2K3A1</i>		<i>3K3A1</i>
	<i>3975K</i>		<i>3975K</i>
	<i>Ambiflex, Johnson</i>		<i>Alerton</i>
	Ω		Ω
-50	150395	-50	200348
-45	112994	-45	150524
-40	75593	-40	100701
-35	57691	-35	76853
-30	39789	-30	53005
-25	30814	-25	41048
-20	21839	-20	29092
-15	16416	-15	21868
-10	12453	-10	16589
-5	9529	-5	12694
0	7353	0	9795
5	5719	5	7619
10	4482	10	5971
15	3539	15	4714
20	2814	20	3748
25	2252	25	3000
30	1814	30	2417
35	1471	35	1959
40	1199	40	1598
45	983	45	1310
50	810	50	1080
55	672	55	896
60	560	60	746
65	468	65	625
70	394	70	526
75	333	75	444
80	282	80	377
85	241	85	321
90	206	90	275
95	177	95	236

No	5	No	6
100	152	100	204
105	132	105	176
110	114	110	153
115	100	115	133
120	88	120	117
125	77	125	102

No Sensor β coefficient Manufacturers °C	7	No Sensor Manufacturers °C	8
	<i>30K6A1</i>		<i>SIE1</i>
	<i>4262K</i>		<i>Barber Colman, Siebe</i>
	Ω		Ω
	<i>Drayton</i>	<i>-50</i>	<i>10732</i>
-30	622911	-45	10624
-25	477393	-40	10517
-20	331876	-35	10344
-15	245785	-30	10172
-10	183697	-25	9913
-5	138502	-20	9654
0	105305	-15	9320
5	60713	-10	8933
10	62347	-5	8496
15	48511	0	8044
20	38019	5	7489
25	30000	10	6938
30	23828	15	6370
35	19046	20	5798
40	15317	25	5238
45	12390	30	4696
50	10079	35	4185
55	8243	40	3707
60	6777	45	3271
65	5600	50	2875
70	4650	55	2521
75	3879	60	2206
80	3251	65	1929
85	2737	70	1685
90	2313	75	1472
95	1963	80	1287
100	1672	85	1127
105	1430	90	986
110	1228	95	866
115	1058	100	760

No	7	No	8
120	915	105	670
125	793	110	590
		115	522
		120	462
		125	410

No Sensor β coefficient Manufacturers $^{\circ}\text{C}$	9	No Sensor Manufacturers $^{\circ}\text{C}$	10
	<i>TAC1</i>		<i>SAT1</i>
	<i>3500K</i>		<i>Satchwell</i>
	Ω		Ω
-40	39024	-45	9652
-35	29358	-40	9584
-30	22284	-35	9467
-25	17073	-30	9349
-20	13192	-25	9159
-15	10276	-20	8968
-10	8068	-15	8708
-5	6382	-10	8396
0	5085	-5	8031
5	4078	0	7614
10	3294	5	7150
15	2676	10	6649
20	2188	15	6121
25	1800	20	5580
30	1488	25	5039
35	1237	30	4513
40	1034	35	4012
45	869	40	3545
50	733	45	3117
55	622	50	2730
60	529	55	2386
65	453	60	2082
70	389	65	1816
75	335	70	1585
80	290	75	1385
85	252	80	1213
90	220	85	1064
95	192	90	937
100	169	95	828
105	149	100	734

No	9	No	10
110	131	105	654
115	116	110	585
120	103	115	525
125	92	120	474
		125	429

No Sensor Manufacturers °C	16	No Sensor Manufacturers °C	16
	<i>Pt1000</i>		<i>Pt1000</i>
	<i>Honeywell, Sauter, Serck, Siebe, Cylon</i>		<i>Honeywell, Sauter, Serck, Siebe, Cylon</i>
	Ω		Ω
-50	803.1	310	2156.1
-40	842.7	320	2191.5
-30	882.2	330	2226.8
-20	921.6	340	2262.1
-10	960.9	350	2297.2
0	1000.0	360	2332.1
10	1039.0	370	2367.0
20	1077.9	380	2401.8
30	1116.7	390	2436.4
40	1155.4	400	2470.9
50	1194.0		
60	1232.4	No	17
70	1270.8	Sensor	Ni1000
80	1309.0	Manufacturers	Sauter
90	1347.1	°C	Ω
100	1385.1	-50	742.6
110	1422.9	-40	791.3
120	1460.7	-30	841.5
130	1498.3	-20	893.0
140	1535.8	-10	945.8
150	1573.3	0	1000.0
160	1610.5	10	1055.5
170	1647.7	20	1112.4
180	1684.8	30	1170.6
190	1721.7	40	1230.1
200	1758.6	50	1291.1
210	1795.3	60	1353.4
220	1831.9	70	1417.2
230	1868.4	80	1482.5
240	1904.7	90	1549.4

No	16	No	16
250	1941.0	100	1617.8
260	1977.1	110	1687.9
270	2013.1	120	1759.8
280	2049.0	130	1833.4
290	2084.8	140	1909.0
300	2120.5	150	1986.6