

LoRaWAN Gateway

LORCOM

User Manual V1.2

English



CONTENTS

1	Introduction	4
2	Hardware Overview	6
3	Technical Data	7
4	Safety Information and Warnings	8
5	Installation	9
6	Configuration	11
6.1	Accessing Web Interface	11
6.2	WebUI Overview	12
6.3	Adding Devices	13
6.3.1	Overview	13
6.3.2	Add device.....	13
6.3.3	Bulk Add Device	16
6.4	Device Profiles.....	17
6.5	Values	19
6.6	Device Library.....	20
6.7	Backup/Restore	20
6.8	Firmware Update	21
7	Data.....	22
7.1	MQTT	22
7.2	Modbus	22
7.2.1	Mapping of Devices.....	22
7.2.2	Modbus Registers	22
7.2.3	RX Values.....	23
7.2.4	Channel Config	23
7.2.5	Channel Labels	24
7.3	BACnet.....	24
8	Other Features.....	24
8.1	Node-RED	24
8.2	Packet Forwarder	25
8.3	Connecting other gateways	25
	Revisions	27

THANK YOU

Thank you for purchasing our product! We believe in your satisfaction with the product that aligns with the company philosophy of the highest care and precision. In case of interesting ideas and concepts, please contact firvena@firvena.cz

www.firvena.com

1 INTRODUCTION

The LORCOM is a LoRaWAN gateway with an integrated *Network server* and built-in integrations to MQTT, Modbus and BACnet. It is designed for indoor use and offers small, compact dimensions. It allows you to extend your building management system with LoRaWAN devices and take advantage of modern, low-power, long-range wireless communication. The gateway also includes Node-RED, which makes it even more flexible. Below is an overview of LORCOM features.

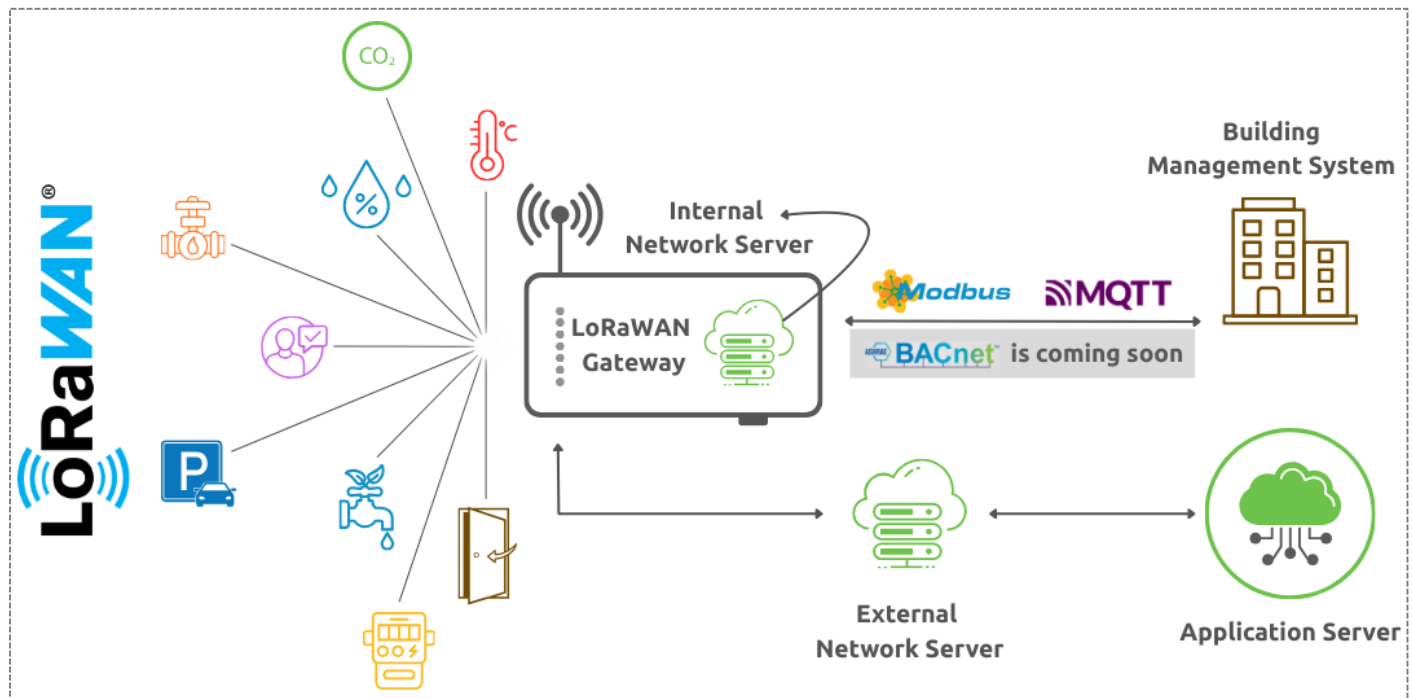

Durable and safe hardware

LORCOM is our own hardware with a powerful and energy-efficient NXP processor with an Arm® Cortex®-A55 core and advanced industrial-grade security. The gateway runs a reliable Linux system based on the Yocto Project.

LoRaWAN chipset Semtech® SX1302

Bidirectional LoRaWAN communication is provided by an 8-channel module based on the new generation Semtech® SX1302 chipset, which offers higher sensitivity and significantly lower power consumption.

Power supply

Power supply can be via PoE (Power over Ethernet) or via an external power supply in the range of 15–30 VDC. Both active and passive PoE are supported.

No licences. No hidden fees.

By purchasing the gateway, you get a full-fledged product with unlimited data points, unlimited LoRaWAN devices and free future upgrades.

Manufactured in EU (CZ)

Each piece is carefully inspected by FIRVENA, this brings exceptional quality.

Webserver

Simple gateway setup using an integrated web user interface, access via a unique name on the local network.

Network server

Thanks to the integrated *Network server (NS)*, the gateway can operate as a standalone unit capable of forwarding decoded data to the BMS system via communication protocols such as MODBUS and MQTT. It also offers easy integration with IoT platforms such as AWS IoT Core, Azure IoT Hub or

Google Cloud Pub/Sub. The gateway can also work as a *Packet forwarder* connected to any external NS (e.g. The Things Stack, ChirpStack or AWS), which ensures efficient device management and seamless data integration into end applications.

Support for new devices

End-device support is provided through flexible configuration files, which in most cases eliminates the need for firmware modification. Users can use pre-built configurations or easily create and customize their own to meet specific application requirements. The solution is fully compatible with the ChirpStack JavaScript codecs that manufacturers commonly provide as part of their LoRaWAN device support.

Modbus

Simple integration of end-devices into BMS via Modbus, configuration via web interface, possibility to export register definitions to CSV file.

Node-RED

Visual programming tool for connecting devices, data and services that allows creating and running custom applications directly inside the gateway.

Time backup

The gateway includes a supercap that ensures accurate time backup for at least 72 hours during power outages.

Support for 1000 LoRaWAN elements

The gateway is designed to serve 1000 elements on the LoRaWAN wireless network.

2 HARDWARE OVERVIEW

On the gateway, there is a power connector, RJ45 Ethernet connector, PoE mode switch, LoRaWAN antenna connector, LED indicators and reset button. The LEDs indicate the system status and activity of communication interfaces; they are very useful for troubleshooting during testing and commissioning of the gateway. The reset button is very useful for troubleshooting network settings.

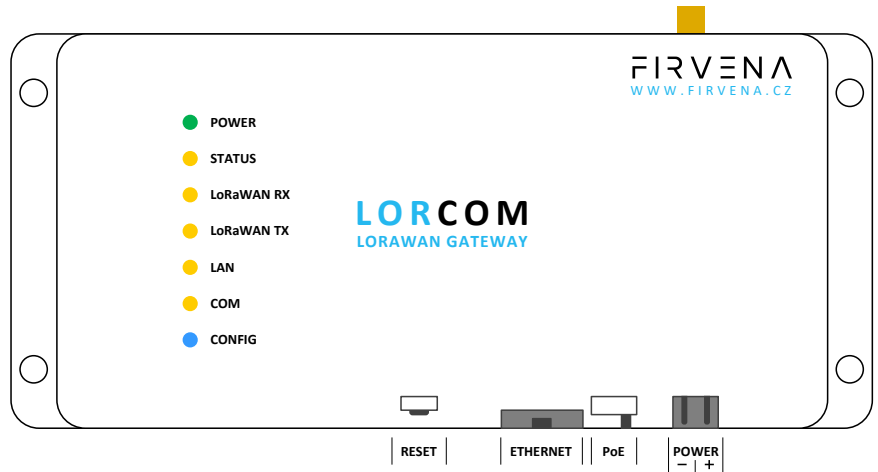

PoE mode switch:

- the “A” position (default) enables the use of ACTIVE power supply
- the “P” position enables the use of PASSIVE power supply

LEDs		Meaning
POWER	●	Power supply and system status
STATUS	●	System status
LoRaWAN RX	●	Uplink packet (incoming)
LoRaWAN TX	●	Downlink packet (outgoing)
LAN	●	Network communication
COM	●	reserved
CONFIG	●	WebUI connection indicator

RESET button functions:

Hold the button to select a command, then confirm the selection, a brief press cancels the selection.

➤ Reboot:

↓hold 1s ▶ STATUS ● on ▶ ↑release ▶ ↓hold 1s ▶ POWER ● off ▶ system is restarting

➤ Network reset:

↓hold 3s ▶ STATUS ● blinking slow ▶ ↑release ▶ ↓hold 1s ▶ STATUS ● blinks 2x ▶ default network configuration used until next reboot.

Use network reset if you are unable to connect to the gateway after changing the network settings.

The following recovery network settings will be used:

- IPv4 DHCP and IPv6 SLAAC enabled
- link-local addresses enabled
- additional fixed address IPv4 **192.168.1.90/24**, IPv6 **fd00::90/64**

➤ Factory reset:

↓hold 10s ▶ STATUS ● blinking fast ▶ ↑release ▶ ↓hold 10s ▶ POWER ● off ▶ system is returning to the factory state, deleting all settings and data

This is the only way to reset the password.

➤ Cancel command selection: ↓↑ short press

⚠ Factory reset is irreversible.
All user settings and data will be lost.

3 TECHNICAL DATA

Category	Parameter	Value
Product	Product name	LORCOM
	Product title	LoRaWAN Gateway
	Vendor name	FIRVENA s.r.o.
Electrical data	Rated power supply	24 VDC, 500 mA
	Supply voltage range	POWER: 15–30 VDC; PoE Active: according to standard 802.3af; PoE Passive: 15–48 VDC
	Power consumption – idle	2.0 W @ 24 VDC (10 % CPU, Ethernet idle)
	Power consumption – full	2.7 W @ 24 VDC (full CPU and Ethernet load)
System	Processor	NXP with Arm® Cortex®-A55 core up to 1.7 GHz
	Memory	1 GB RAM; 8 GB eMMC
	Operating system	Yocto-based Embedded Linux
	Interfaces	1x Gigabit Ethernet; 1x LoRaWAN SX1302 EU868
Ethernet	Speed	1000/100/10 Mbit/s
	Connector	RJ45
	PoE	Yes (according to standard 802.3af)
LoRaWAN	Chipset	Semtech® SX1302
	Region	EU868
	Frequency	863–870 MHz
	Sensitivity	–125 dBm @ 125kHz/SF7 –139 dBm @ 125kHz/SF12
	TX Power	14 dBm
	Connector	SMA (female)
	Number of channels	8 channels
	Network server	Yes
	Number of devices	1000 devices
	LoRaWAN versions	1.0.0, 1.0.1, 1.0.2, 1.0.3, 1.0.4, 1.1.0
	Device classes	CLASS A, CLASS B, CLASS C
Antenna	Band	868 MHz ISM
	Frequency	863–870 MHz
	Peak gain	3.0 dBi
	Connector	SMA (male)
	Dimensions	170 × 18 × 10 mm
Physical	Housing material	Plastic – ABS, white

	IP Code	IP20
	Operating temperature	-20 °C to +70 °C
	Relative humidity	max. 80 %
	Dimensions without antenna	190 × 86 × 35 mm (W × H × D)
	Weight without antenna	260 g

4 SAFETY INFORMATION AND WARNINGS



Please follow the general safety regulations. This device may only be installed by a qualified person (accredited electrician) and after reading these instructions. Improper installation can result in health, property or equipment damage.

The product meets the general safety regulations. The protection Cover IP 20 allows installation only in normal, dry space.

The gateway must be powered from a safe voltage source that meets the requirements for input voltage range and must be installed in accordance with national and general safety standards.

Follow the safety instructions and applicable standards for the country and location of installation. The product may only be used in accordance with this manual.

To avoid the risk of electrical shock or fire, the maximum operating parameters of the gateway must not be exceeded.

Use only unmodified products.

Only cable types with sufficient cross-section and insulation properties may be used for the connection.

STORAGE

The device must be stored in a temperature range 0-40 °C and a relative humidity of up to 80 %, and non-condensing spaces. Products must not be exposed shock, harmful vapors or gases.

REPAIRS

Products are repaired by the manufacturer. Products to be repaired are shipped in a package that ensures shock absorption and protects the products against damage during shipment.

WARRANTY

The product is warranted 24 months from the date of delivery that is mentioned on the delivery note. The manufacturer only guarantees properties and parameters that are explicitly described in the technical documentation. Claims, complaints and returns must be directed exclusively to the manufacturer. The complaint must contain the exact product identification, delivery note number and defects description. The manufacturer is not responsible for defects caused by improper storage, improper external connection, damages caused by external influences especially due to unacceptable size, incorrect adjustment, improper installation, incorrect operation or normal wear and tear.

PRODUCT DISPOSAL



The product does not belong to municipal waste. The product must be disposed to the separate waste collection with the possibility of recycling, according to local regulations and legislation. The product contains electronic components.

5 INSTALLATION

Dimensions (in mm)

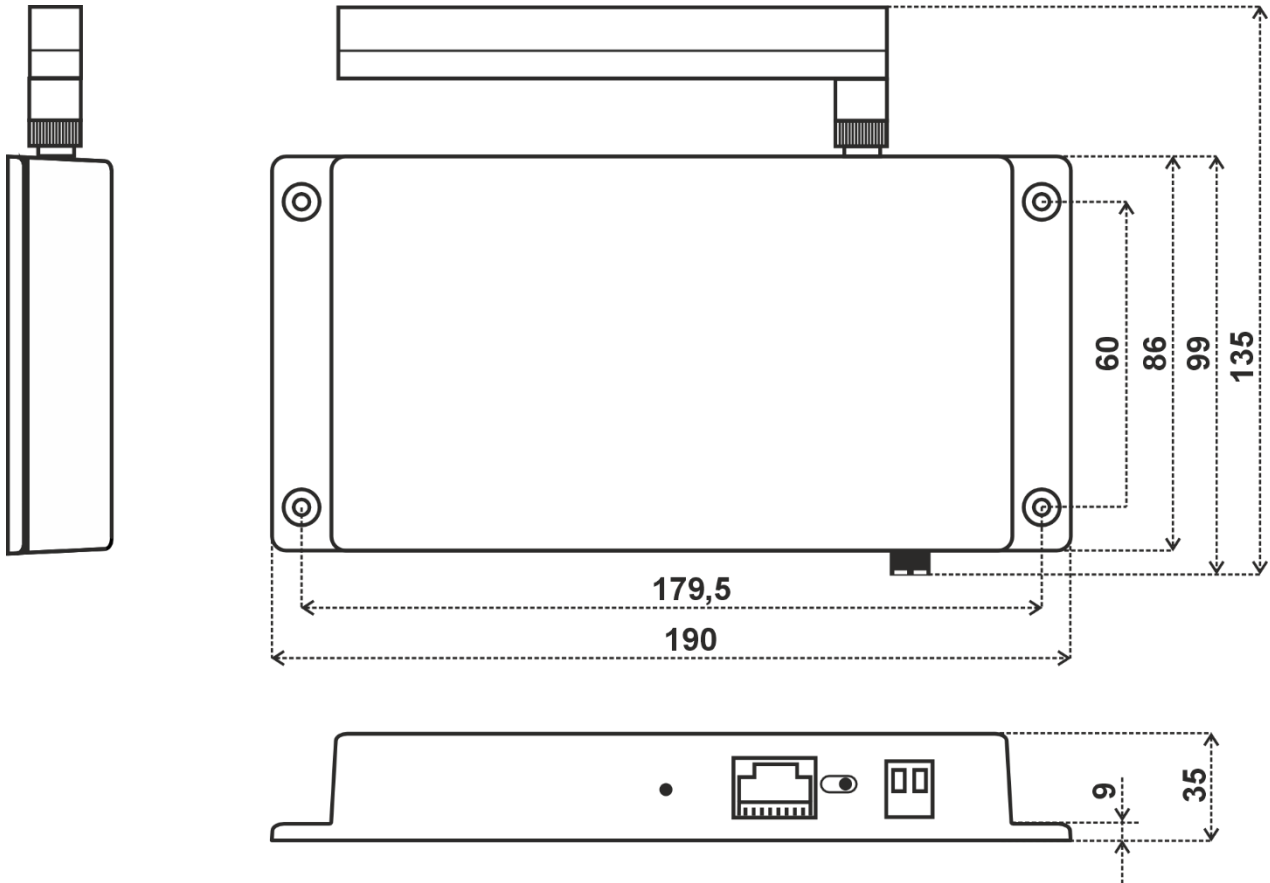

Mounting

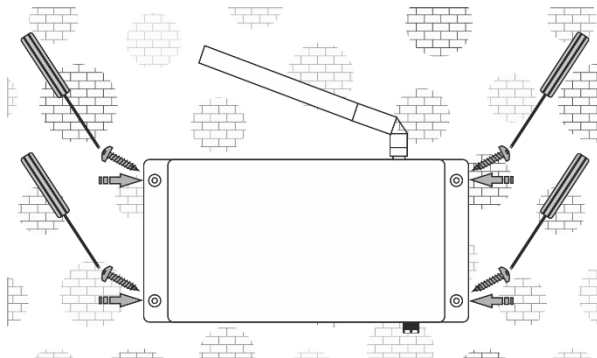

The gateway is fixed by using plastic anchors and Phillips screws to the wall or solid surfaces of suspended ceilings making sure that it is in a good radio position for receiving and transmitting signals. When located in shielded surfaces, the standard supplied antenna can be replaced with another permitted antenna type for the 868 MHz frequency with an SMA (Male) connector.

Power supply

There are two possible power supply connections:

1. Power supply via PoE (Power over Ethernet):

The device supports PoE according to the 802.3af standard, network elements must support this type of power interface. To use passive PoE, set the switch next to the ETHERNET connector to the left position.

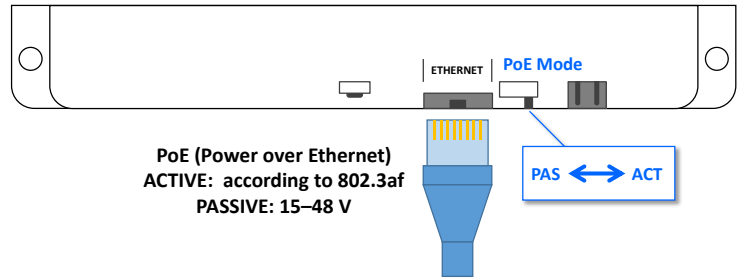

2. Power supply from an external source:

The gateway must be powered from a safe voltage source that meets the input voltage range requirements. The electrical installation must be in accordance with national requirements and safety standards.

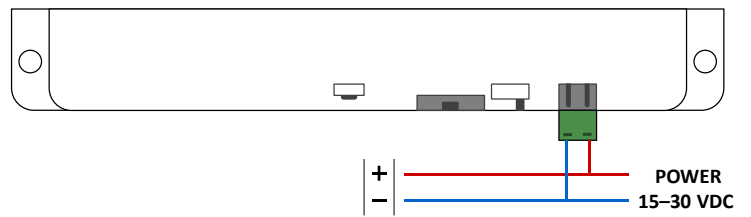

6 CONFIGURATION

6.1 Accessing Web Interface

The gateway has an integrated web application (*WebUI*) that allows configuration using a web browser. This section describes how to open *WebUI* for the first time.

Power on the gateway and connect it to the local network via the ETHERNET connector, or connect it directly to a computer with an Ethernet adapter. The gateway should automatically obtain an IP address and other network parameters from a DHCP server, if available, or use automatic address configuration methods.

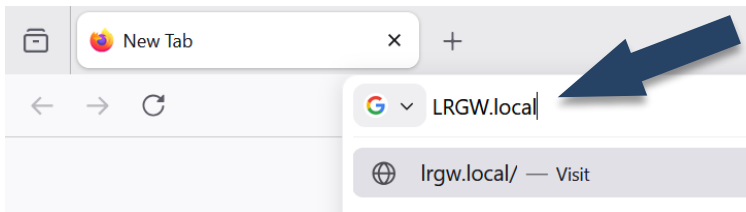

The *WebUI* is available on **HTTP port 80**, each gateway has a universal name that works in the local network, simply enter “<http://LRGW.local>” into the address bar of your web browser (letter case does not matter, you can write *lrgw.local*).

Login is required. The default password is “123”; you must change the password before continuing. The blue CONFIG  should light up after login.

The connection using LRGW.local may not work for several reasons:

1. Multiple gateways on the same network (name conflict)

If multiple gateways are connected to the same local network, the names are numbered, e.g.: *LRGW.local*, *LRGW-2.local*, *LRGW-3.local*, ... You can try the numbered versions and watch the CONFIG LED.

The gateway has also a unique name *LRGW-XXXXXX*, which is printed on the product label, the second part are the last six characters from the MAC address, e.g.: <http://LRGW-4BAC34.local>.

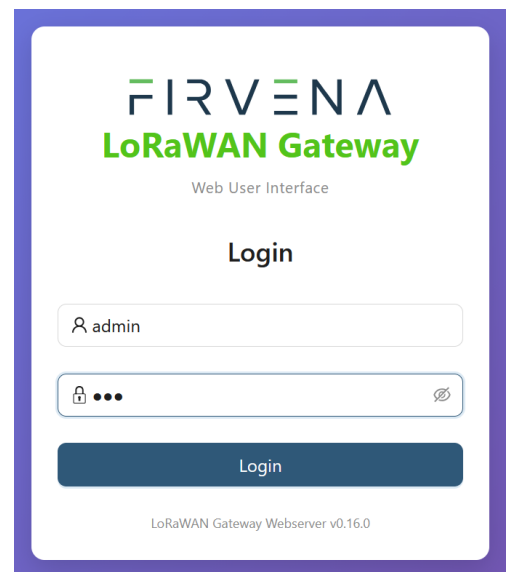

2. Blocked mDNS or missing mDNS client; or gateway has other subnet or incorrect network settings

You will need the IP address.

One simple method always works: do the *Network reset* using the RESET button – see [Hardware Overview](#) and use the fixed IPv4 or IPv6 address: <http://192.168.1.90> or <http://fd00::90>.

Configure your computer to have the same subnet and a different IP address, e.g. 192.168.1.95 (subnet mask 255.255.255.0), fd00::95 (prefix length 64), you should be able to connect to the gateway and check/repair its network settings.



- It takes some time for the gateway to boot, the ready state is indicated by STAUS  off.
- If the password is lost, you need to perform a *Factory reset* using the RESET button.
- The default addresses *192.168.1.90* and *fd00::90* only work after the *Network reset* and until the next *Reboot*.

Other access options

DHCP Server: You can check the DHCP clients list if you have access to the local DHCP server (usually through the configuration interface of your router). Look for the client name “*LRGW-XXXXXX*” (same as unique name). To access the *WebUI*, enter the IP address to the address bar of your web browser.

File Explorer in Microsoft Windows (SSDP, UPnP): The gateway is visible as a network device on the Microsoft Windows operating system in [File Explorer > Network]. SSDP stands for Simple Service Discovery Protocol, it is an alternative to mDNS.

Double click on the device item to open the WebUI. [Right click > Properties] will display additional information.

If the gateway is not there, try to refresh the list: [Click on the list > press F5 key] or [Right click > Refresh].

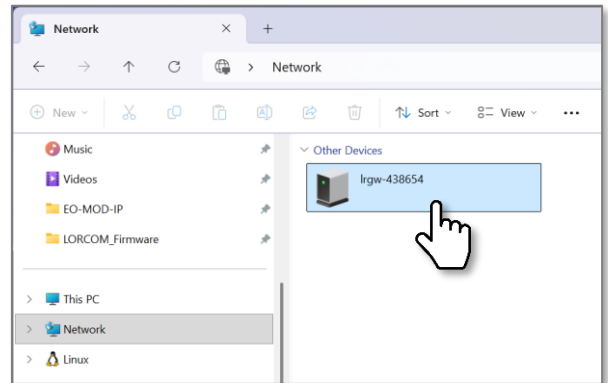

6.2 WebUI Overview

1. Menu:

Dashboard: an overview of all applications and devices

Applications / Devices: view application and device details

Device profiles: view device profile definition (a configuration shared by devices of the same type)

Modbus: Modbus overview of all applications and devices

Settings: system settings (network, firmware update, password, ...)

Advanced: advanced configuration options

Node-RED: open the Node-RED in a new tab

2. Content

3. Content title

4. Navigation breadcrumb with back and forth buttons

5. Logout

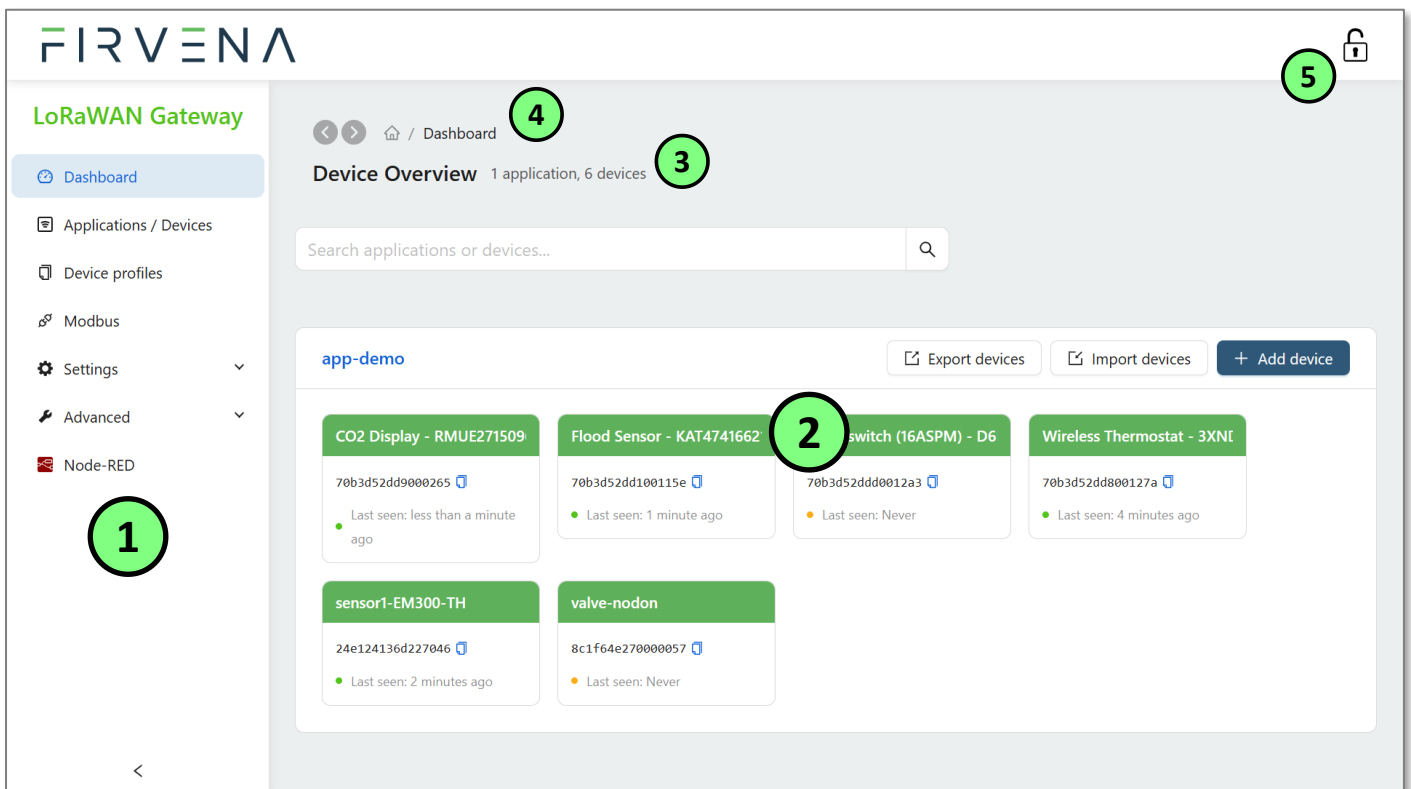

6.3 Adding Devices

6.3.1 Overview

The devices are organized into groups called “*Applications*”. Devices of different type can live under the same application. Each device belongs to one application; it cannot be used in multiple applications.

The division into applications affects other parts of the system in a way that simplifies the subsequent configuration, especially for large projects. You can filter devices by application in MQTT; in Modbus, each application has its own Modbus server. How you use the applications is up to you; for example, each room or floor can be one application, or power measurement and room control can be applications. It is also possible to use one application for everything.

Another important term is “*Device profile*”. This shared configuration applies to all devices of the same type that have the same profile in their settings. The purpose of profiles is to separate generic device settings. Changing the device profile will affect all devices that use it.

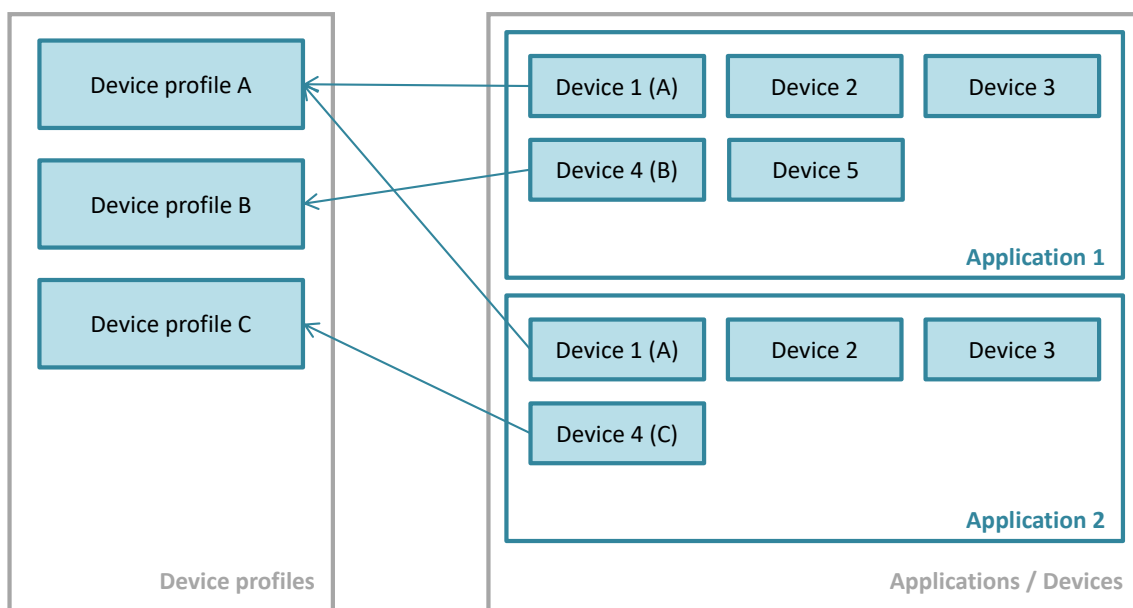

6.3.2 Add device

We will use MClimate’s CO2 sensor as an example.

1. Choose/create an application (app-demo)
2. Use [Dashboard > Add device]
or [Applications / Devices > Application details > Devices > Add device]
3. Fill in the **Name** and **Device EUI**
4. Choose/create a **Device profile** – see [Device Profiles](#)
5. Save

app-demo **1**

Export devices Import devices + Add device **2**

Flood Sensor - KAT4741662	Relay switch (16ASPM) - D6	Wireless Thermostat - 3XNI	sensor1-EM300-TH
70b3d52dd100115e	70b3d52dd0012a3	70b3d52dd800127a	24e124136d227046
Last seen: 25 minutes ago	Last seen: 5 minutes ago	Last seen: 1 minute ago	Last seen: 9 minutes ago

FIRVENA

LoRaWAN Gateway

Dashboard Applications / Devices Device profiles Modbus Settings Advanced Node-RED

Applications / Devices / Add

Add device

* Name **3** Scan QR code

Description

* Device EUI (EUI64) Join EUI (EUI64)

* Device profile **4** Edit profile Add profile Import profile

> Advanced **5** Save Cancel

i You can omit Join EUI (formerly App EUI), it will be set automatically from device join request. In fact, it is not used at all, because no external *Join server* is used.

The next step is to configure security key(s):

6. Use [Device details > OTAA keys]
7. Enter a unique **Application key**, which must match the key stored in the device
8. Save

 ➤ The Application key is fixed (provided by the manufacturer) or sometimes configurable on the device. Contact the manufacturer or seller; for example, MClimate sends the keys in a CSV file.

 **Keep the OTAA keys secret and do not print them on the device**
 These keys are used to secure the communication between the device and application.

Now you can activate the device to start the *OTAA Join* procedure. *OTAA Join* is usually triggered by inserting the battery, using a reset button or using another control interface on the device – follow the device documentation.

You can watch the *Device events* log:

The device status should go green:

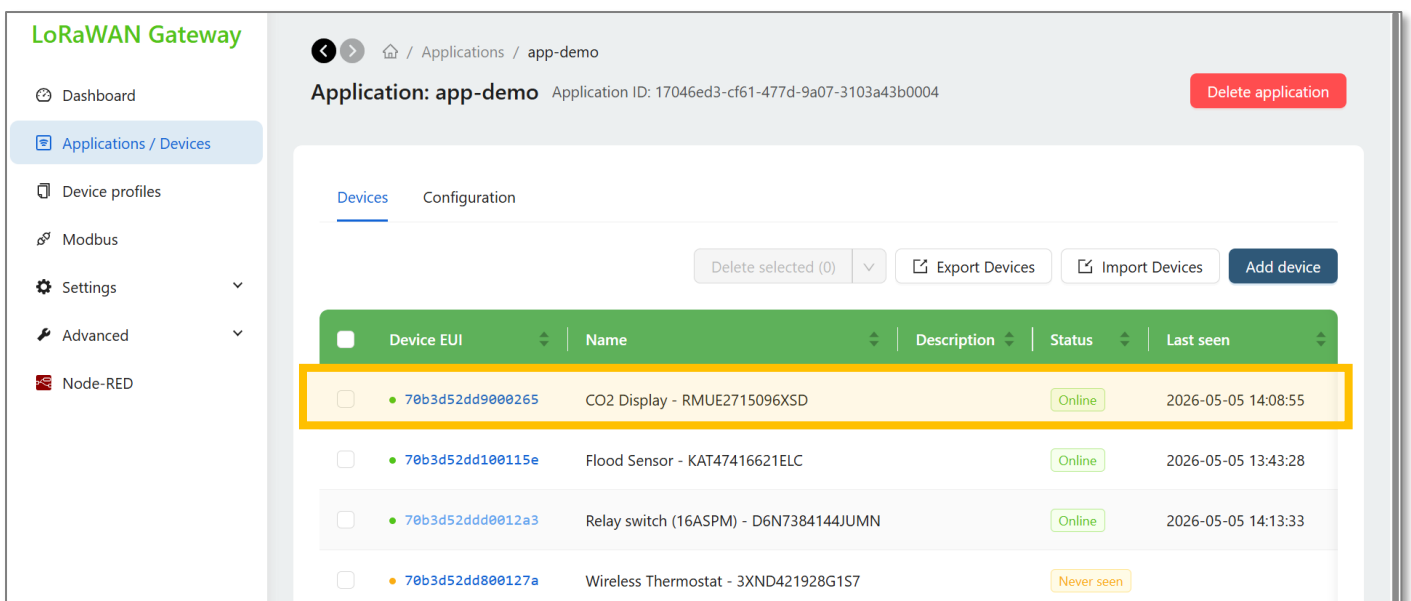
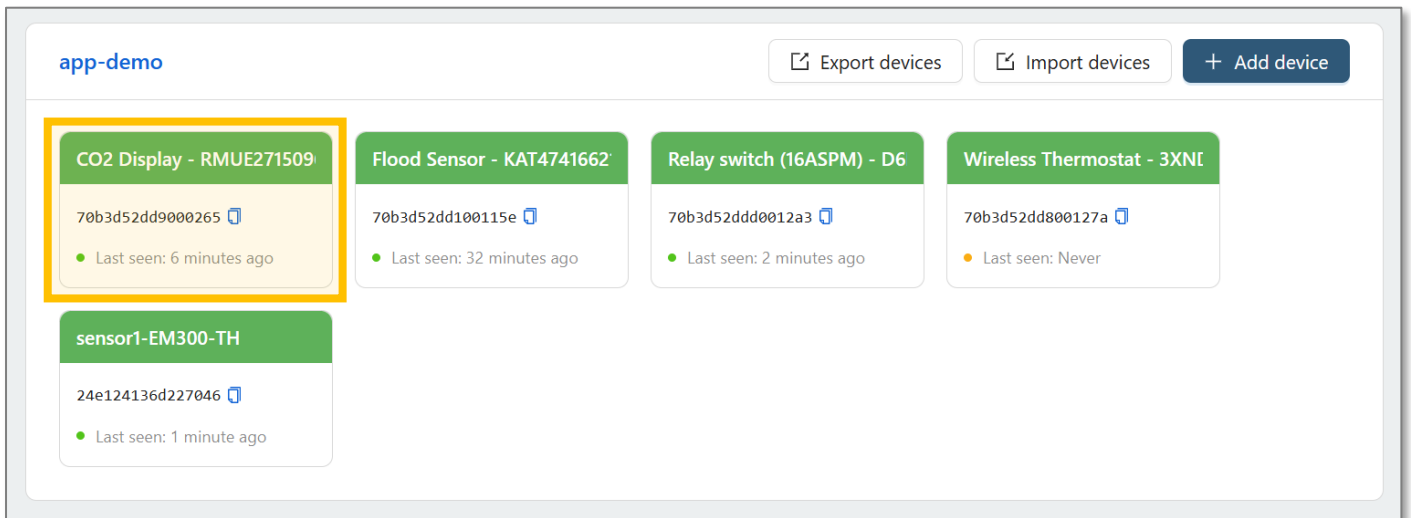

6.3.3 Bulk Add Device

You can import multiple devices from a CSV file. This saves a lot of time.

1. Choose/create an application (app-demo)
2. Use [Dashboard > Import devices]
or [Applications / Devices > Application details > Devices > Import devices]
3. Upload the file
4. You will go through a validation logic
5. Proceed

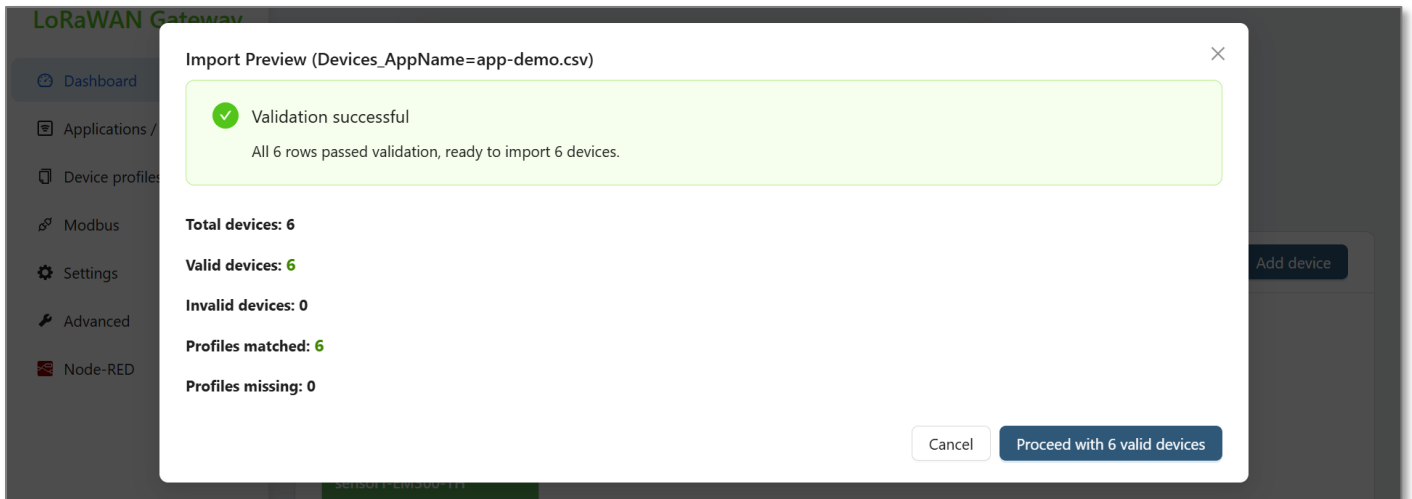
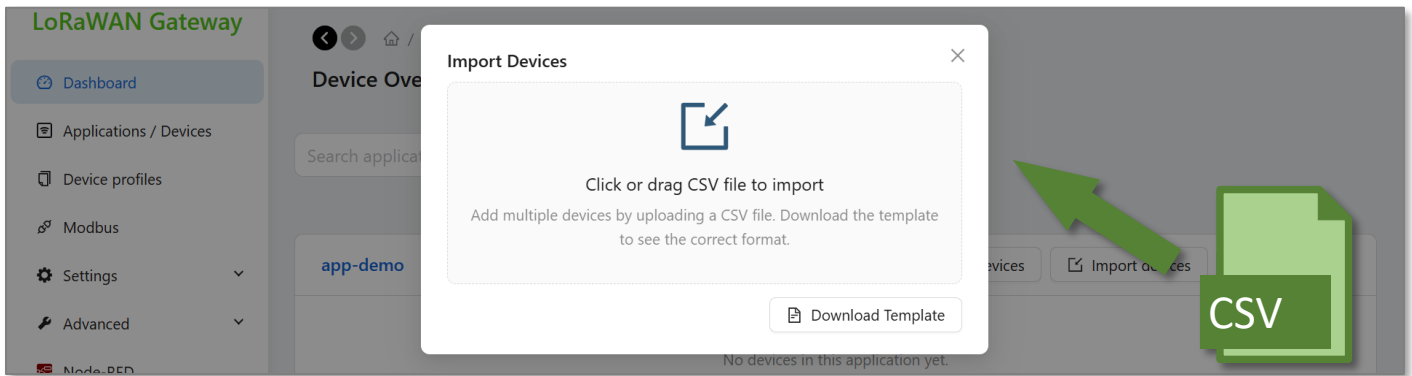

i ➤ Device profiles are matched based on their name, so a device profile with the same name as in the “deviceProfileName” column must exist prior to the import.

6.4 Device Profiles

To add a device profile:

1. Use [Device profiles > Add device profile]
2. Fill in the parameters manually or choose a template
You should find the parameters in the datasheet or device support from the manufacturer. Leave the default values if you are not sure what values to set, you can refine it later.
3. Save

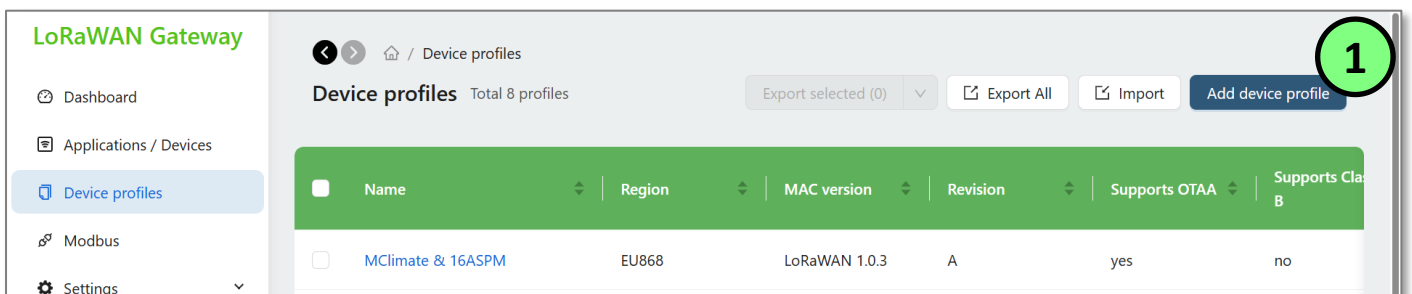

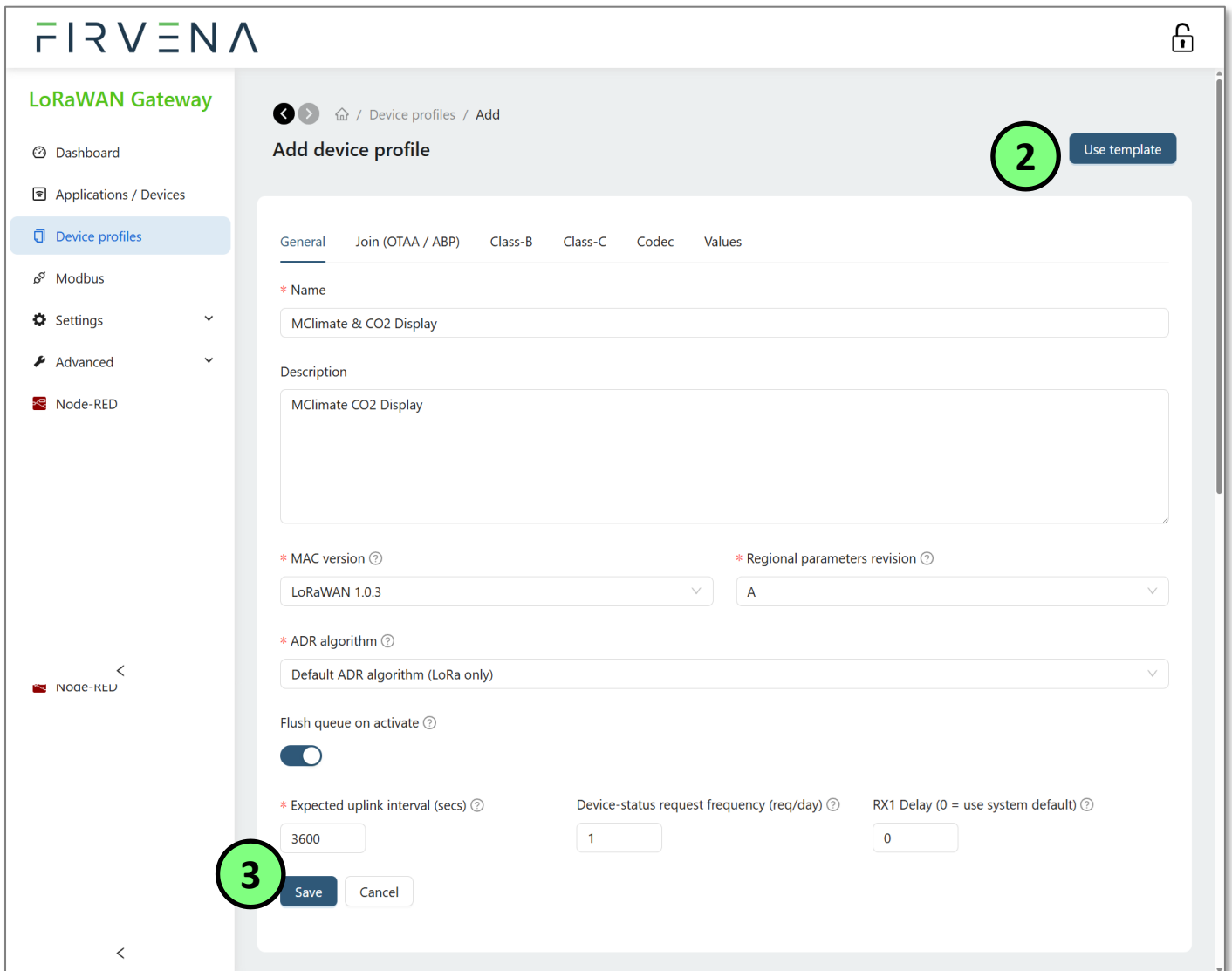

Using a template

You can “Duplicate” an existing profile or search for the device in the “Library”:

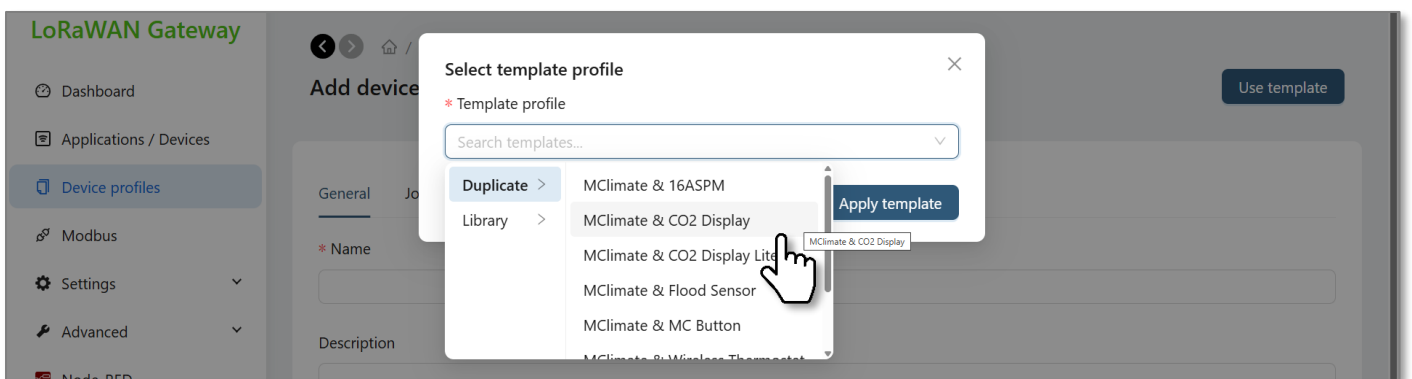

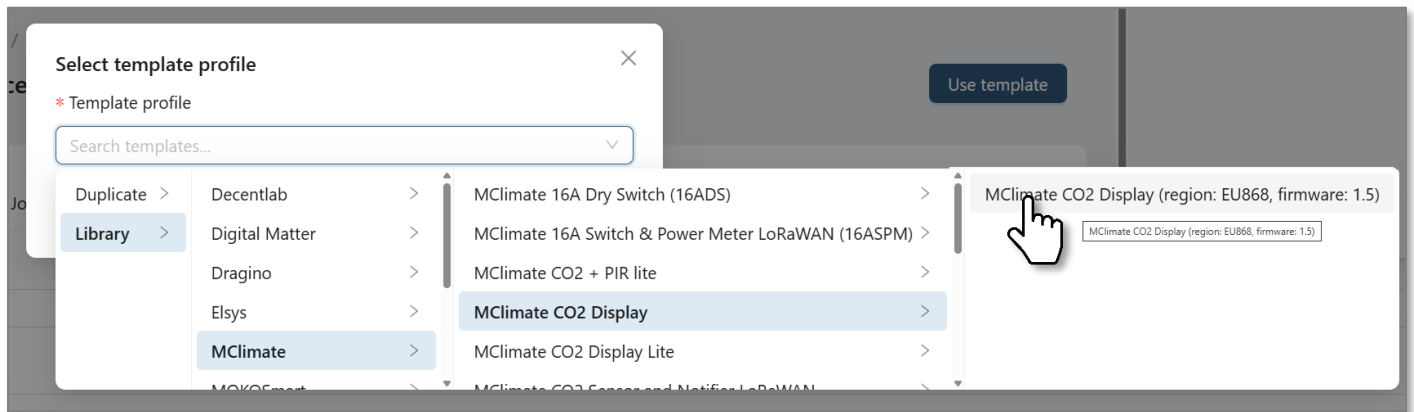

General recommendation for library firmware version selection: Choose the highest available firmware version that is lower than your device firmware version and has the same major version number, for example:

- your device V1.8; available templates V1.3, V1.4, V1.5 → choose V1.5
- your device V1.8; available templates V1.3, V1.4, V1.5, V1.8, V2.0 → choose V1.8

Export/Import device profiles

You can also import/export the profiles to use them in another gateway:

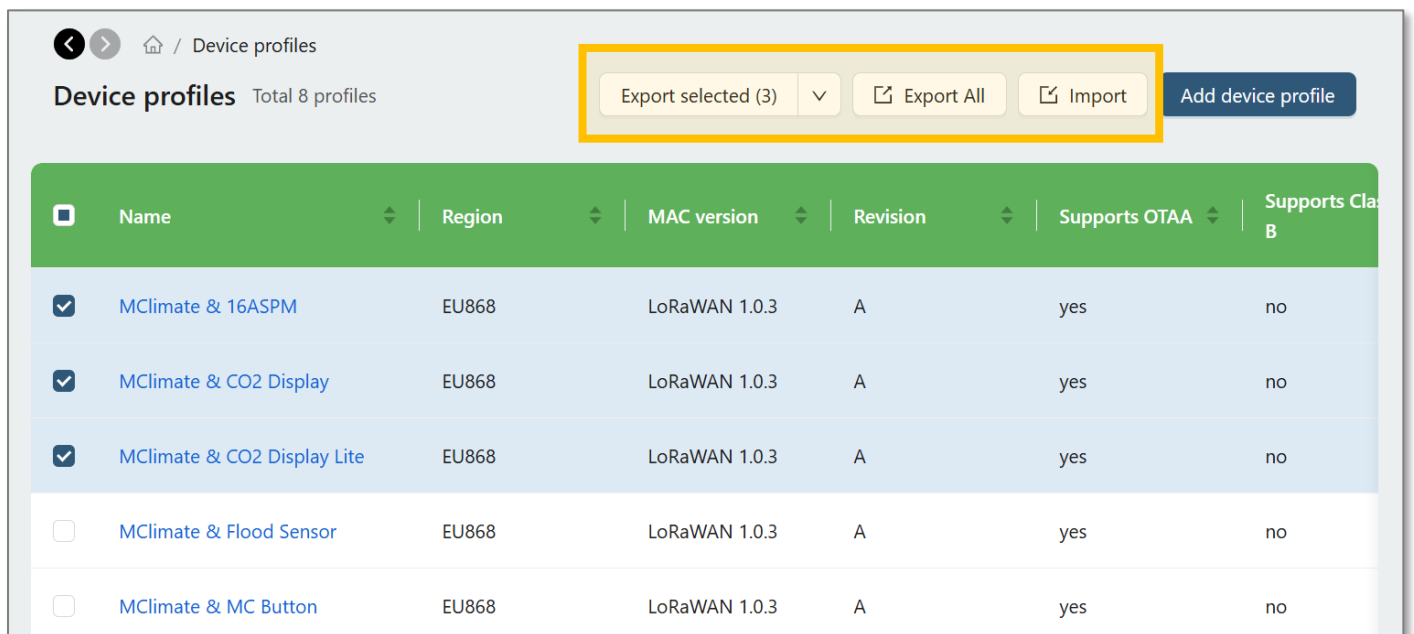

6.5 Values

The configuration “Values” in device profile is used to create the [Device details > Values] table; it is also used to create Modbus registers.

LoRaWAN Gateway

Dashboard

Applications / Devices

Device profiles

Modbus

Settings

Advanced

Node-RED

Applications / app-demo / Devices / CO2 Display - RMUE2715096XSD

Device: CO2 Display - RMUE2715096XSD Device EUI: 70b3d52dd9000265 Delete device

Configuration **Values** OTAA keys Activation Downlink queue Device events LoRaWAN frames

Key	Direction	Index	Type	Current Value	Last Updated	Write Value
ppm	RX	0	Number	963.00	9m ago	-
sensorTemperature	RX	1	Number	23.40	9m ago	-
relativeHumidity	RX	2	Number	34.38	9m ago	-
lux	RX	3	Number	254.00	9m ago	-
pir	RX	4	Boolean	false	9m ago	-
batteryVoltage	RX	5	Number	3.04	9m ago	-

Modbus registers:

RxValues.mbp

Tx = 1699: Err = 0: ID = 1: F = 03: SR = 1000ms

	Name	00000	Name	00010	Name	00020	Name	00030	Name	00040	Name	00050	Name
0	V1	963	V11	0		0		0		1		0	
1	V2	234	V12	0		0		0		0		0	
2	V3	344	V13	0		0		0		0		0	
3	V4	254	V14	0		0		0		0		0	
4	V5	0	V15	0		0		0		0		0	
5	V6	304	Uplink counter	1		0		0		0		1	
6	V7	0	Timestamp	1777985381		0		0		0		27129	
7	V8	0		--		0		0		0		-6067	
8	V9	0	RSSI	-101		0		0		0		-67	
9	V10	0		0		0		0		0		0	

6.6 Device Library

The gateway contains a library of LoRaWAN end-devices with predefined configurations. This library is being continuously extended in new firmware releases. The device library is used as a source for the device profile templates – see [Using a template](#)

6.7 Backup/Restore

The overall system backup is not supported. You can backup device profiles and devices by exporting them.

Device profiles export/import:

Device profiles Total 8 profiles

Name	Region	MAC version	Revision	Supports OTAA	Supports Class B
MClimate & 16ASPM	EU868	LoRaWAN 1.0.3	A	yes	no
MClimate & CO2 Display	EU868	LoRaWAN 1.0.3	A	yes	no

Per-application device export/import:

Application: app-demo Application ID: 194eb949-ca82-4989-8242-9fed28fbb826

Devices Configuration

Device EUI	Name	Description	Status	Last seen
70b3d52dd9000265	CO2 Display - RMUE2715096XSD		Never seen	
70b3d52dd100115e	Flood Sensor - KAT47416621FLC		Never seen	

⚠ The exported CSV contains the OTAA keys, keep it secret
 These keys are used to secure the communication between the device and application.

6.8 Firmware Update

The firmware is constantly being improved and extended to support new features. The latest version is available for download on FIRVENA website in the [Downloads section](#). Download the file and upload it to the gateway using *WebUI* in [\[Settings > Firmware update\]](#):

Network

MQTT

Firmware update

Password

Advanced

Node-RED

Click or drag firmware file to upload
 Accepts: .bin or .zip files. Zip files must contain exactly one .bin file

Selected: LRG1_firmware_v0.16.0.bin
 Size: 157.06 MB

Start Upload

ZIP

7 DATA

7.1 MQTT

The gateway has an internal MQTT broker with two interfaces: **public and private**. The public interface is **0.0.0.0:1883**, it is only used for packet forwarder topics `eu868/gateway/<gateway_id>/#`. The gateway messages correspond to log items recorded in [Advanced > LoRa Gateways > Gateway details > LoRaWAN frames] (http://LRGW.local/#/advanced/lora/gateways/<gateway_id>/frames).

The private interface is **127.0.0.1:1884** and it is not exposed outside the system. This interface exposes application topics with decrypted and decoded data of end-devices. The device topic is `application/<application_id>/device/<device_id>/#`, following the events/commands. The device messages correspond to log items shown in [Device details > Device events] (http://LRGW.local/#/applications/<application_id>/devices/<device_id>/events). Per-device gateway messages are in [Device details > LoRaWAN frames].

Messages from the local packet forwarder are in the *Protobuf* binary format. The application messages are in JSON format.

The local MQTT communication is forwarded to an external MQTT broker using a bridge. It is configured in [\[Settings > MQTT\]](#)

7.2 Modbus

The Modbus configuration is in [\[WebUI > Modbus\]](#)

7.2.1 Mapping of Devices

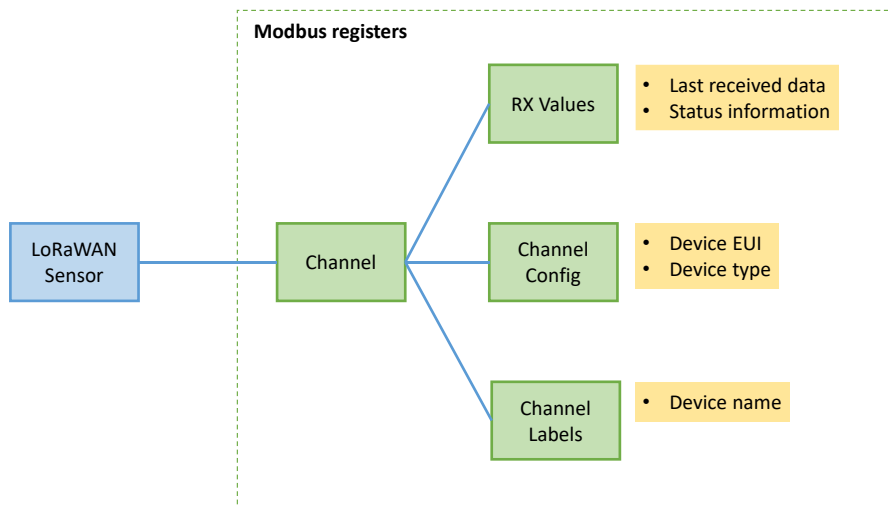

7.2.2 Modbus Registers

Area name	Address range	Access	Description	Channel	Base address
RX Values	0...3999	R	Last received data and channel status	CH1	0
				CH2	20
				...	
				CH200	3980

Reserved					
Channel Config	10000...13999	R, P	Channel configuration (assignment of LoRaWAN device)	CH1	4000
				CH2	4020
				...	
				CH200	13980
Reserved					
Channel Labels	20000...29999	R, P	User defined descriptions of channels	CH1	10000
				CH2	10050
				...	
				CH200	29950
Reserved					

7.2.3 RX Values

For each channel, 20 registers are reserved. When the gateway receives data from the assigned device, and it supports the device, it converts the data contents into *RX Values*. The received data fields are stored in registers from V1 up. The number of values and their meaning depends on the type of LoRaWAN device and on the Device profile configuration.

Address = BaseAddress + Offset

BaseAddress = 0 + 20 · (ChannelNumber – 1)

Group	Offset	Access	Name	Description	Value range
Values	0	R	V1	Value 1	Depends on device type
	1	R	V2	Value 2	
	2	R	V3	Value 3	
	3	R	V4	Value 4	
	...	R			
	14	R	V15	Value 15	
Status	15	R	Uplink counter	Incremented on values refresh	0...65535 (overflows to zero)
	16	R	Timestamp HI	UNIX Timestamp (seconds since 1 Jan 1970 00:00:00 UTC)	UINT32, 0...2 ³² -1 s (0: time not configured)
	17	R	Timestamp LO		
	18	R	Signal	Signal strength (RSSI value)	

7.2.4 Channel Config

For each channel, 20 registers are reserved. The *EUI* uniquely identifies a device within the environment.

Address = BaseAddress + Offset

BaseAddress = 4000 + 10 · (ChannelNumber – 1)

Offset	Type	Access	Name	Description	Example*
0	UINT8[6]	R, P	Device EUI	Unique identifier of the assigned device, array of bytes b0...b7	0x70B3
1					0xD52D
2					0xD900
3					0x0265

4...9		Reserved	
-------	--	----------	--

*Example: Device EUI = 70b3d52dd9000265.

7.2.5 Channel Labels

For each channel, 50 registers are reserved. These registers are designed to store a friendly name of the assigned LoRaWAN device that helps to identify it. The maximum size of *Label* is 98 bytes.

Address = BaseAddress + Offset

BaseAddress = 10000 + 40 · (ChannelNumber – 1)

Tab. 7.1 Channel labels

Offset	Type	Access	Name	Description	Example*
0	UINT8	R, P	Label length (N)	Number of bytes in the Label array	9
1...49	UINT8[98]	R, P	Label	Array of bytes b0...b(N-1)	0x4D79 ("My") 0x2073 (" s") 0x656E ("en") 0x736F ("so") 0x7200 ("r") 0x0000 ... 0x0000

*Example: Label = "My sensor".

7.3 BACnet

The BACnet configuration is in [\[WebUI > BACnet\]](#)

8 OTHER FEATURES

8.1 Node-RED

To open the Node-RED development environment, use [\[WebUI > Node-RED\]](#). It is on the same port as *WebUI* under the root path */nodered*, for example: <http://LRGW.local/nodered>. The same login as for *WebUI* is required.

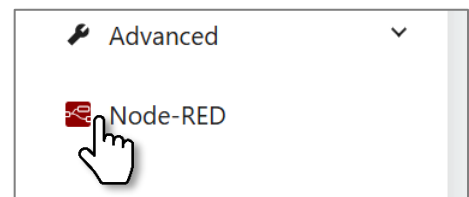

There is a demo showing how the local MQTT broker works:

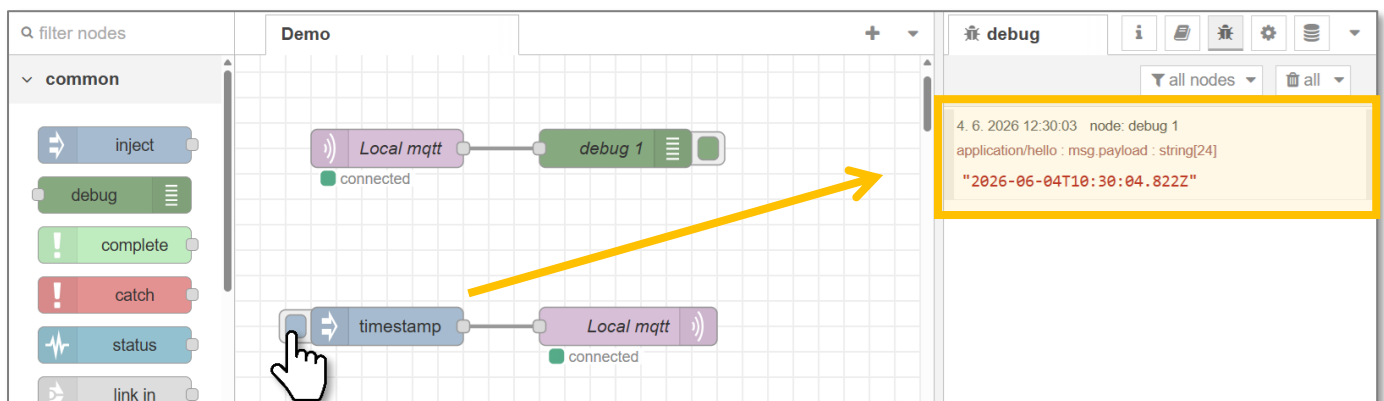

Any changes must be “*deployed*” before use (changed nodes and flows are marked with a blue dot):

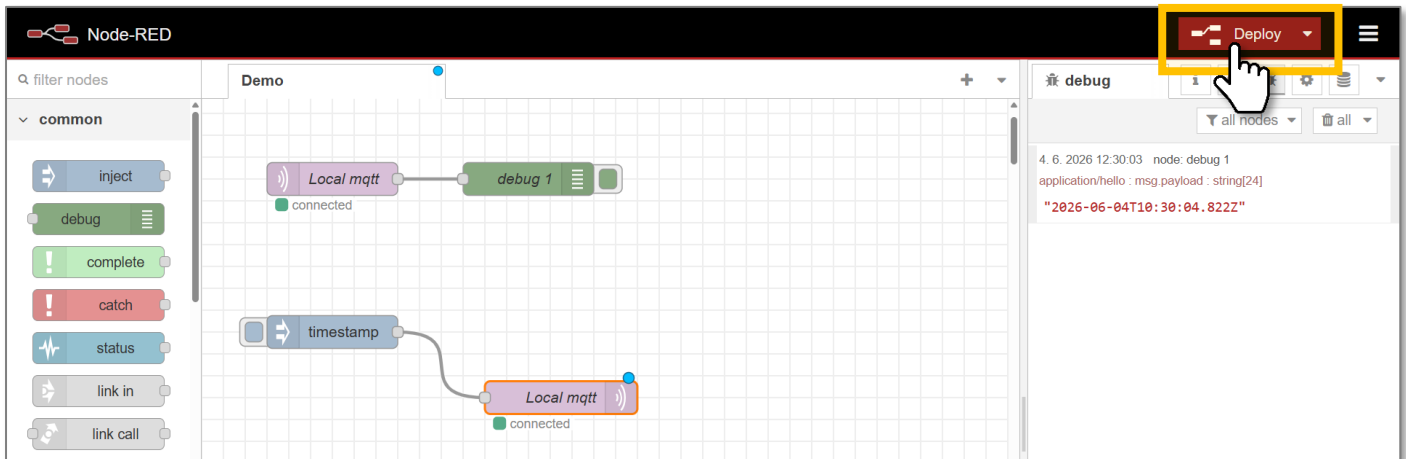

Nodes having an error are marked with a red triangle:

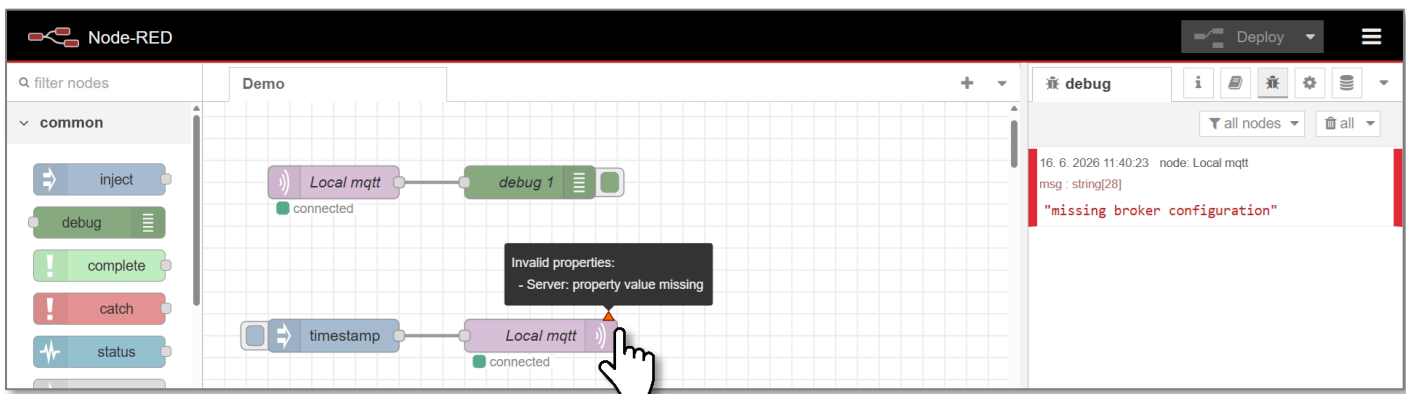

 See <https://nodered.org> for more information about Node-RED.

8.2 Packet Forwarder

[\[WebUI > Advanced > Packet Forwarder\]](#)

The gateway can work as a *Packet forwarder* to an external *Network server*.

Available forwarder types:

Name	Description
UDP Forwarder	UDP Forwarder compatible with the Semtech UDP forwarder protocol. This forwarder is not recommended for production environment. Simple, but weak security and scalability. Software used: https://github.com/chirpstack/chirpstack-udp-forwarder
ChirpStack MQTT Forwarder	Packet forwarder used in ChirpStack ecosystem, it requires an MQTT broker between the gateway and Network server. Simple, security depends on MQTT setup, scalable. Software used: https://github.com/chirpstack/chirpstack-mqtt-forwarder

8.3 Connecting other gateways

[\[WebUI > Advanced > LoRa Gateways\]](#)

Other LoRaWAN gateways can connect to the internal *Network server*. There is always one “local” gateway, which is the packet forwarder running inside the system.

This can be used to extend the range by simple packet forwarders, with this device as a central point collecting the data from edge gateways. The number of gateways must not exceed 10 gateways. The number of end-devices is limited by system resources, which may vary depending on the specific application, the gateway should be able to handle at least 1000 end-devices.

Supported packet forwarders: ChirpStack MQTT Forwarder.

REVISIONS

Date	Version	Description
2026-05-07	V1.0	Initial release
2026-05-19	V1.1	Technical data addition
2026-06-17	V1.2	Style: bold emphasis bolder; uppercase lrgw->LRGW; Update&expand: Accessing Web Interface; Node-RED;